

CLAMPING	SPARE PARTS	ALLOCATION OF PARTS	INDEX	CHANGES	DATE	NAME
		DIAMETER				
-	1	50				
-	-	-				
-	-	-				
-	-	-				
-	-	-				

UNEQUAL POSITIONING

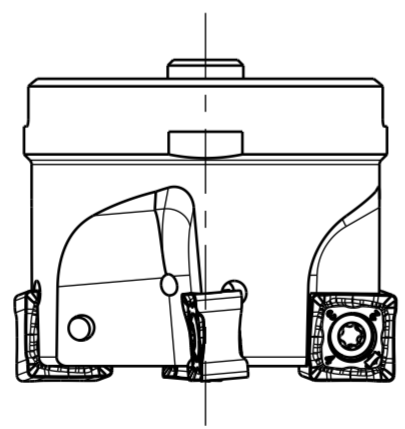
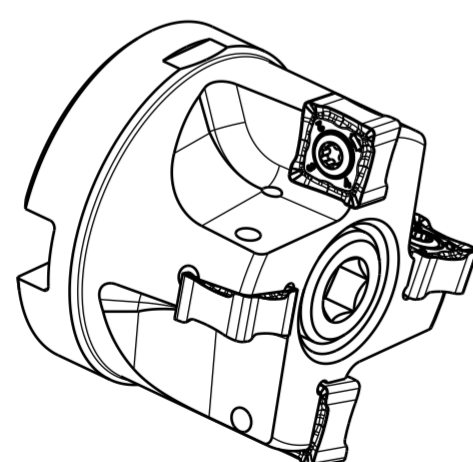
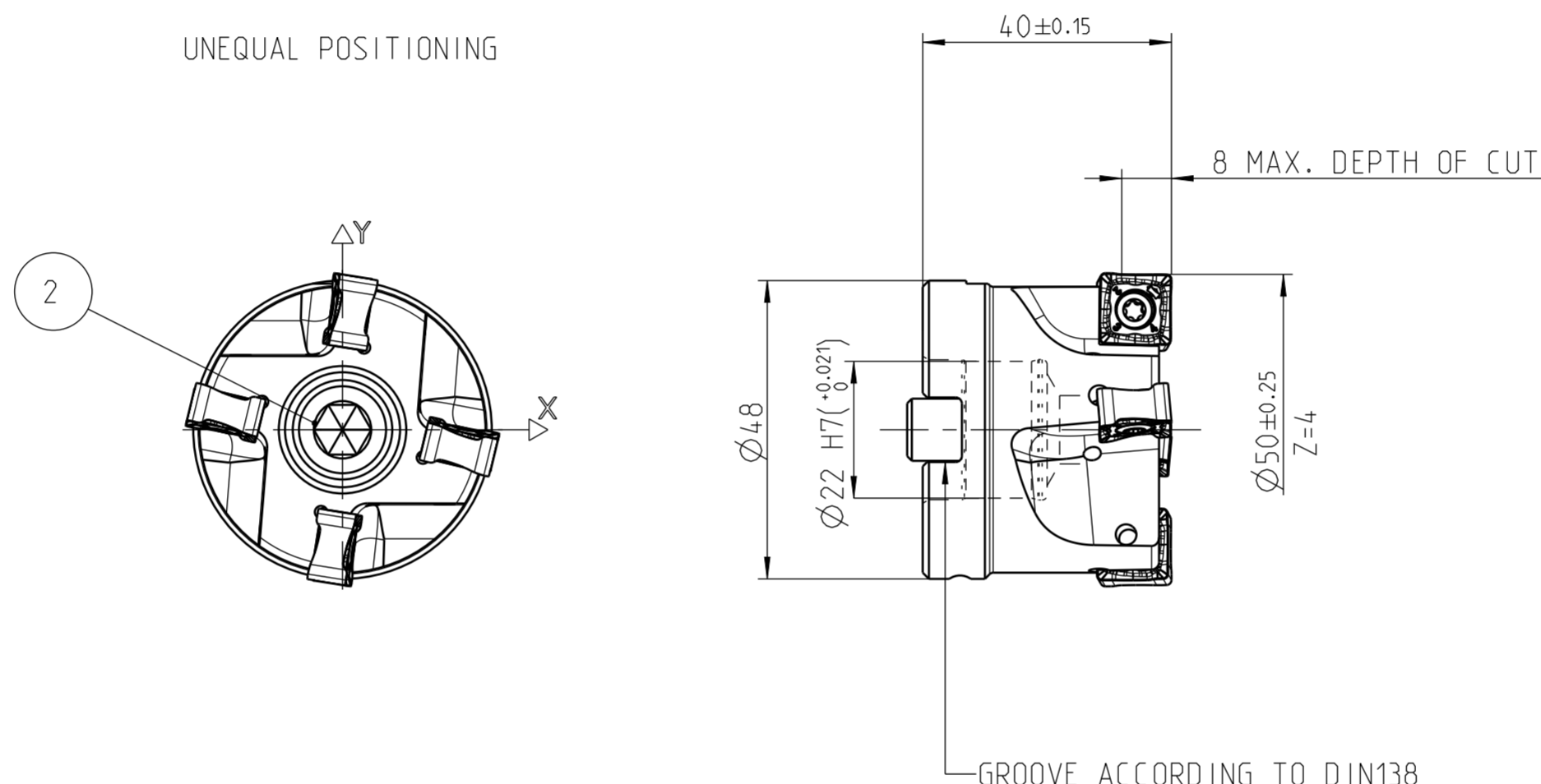

BALANCE GRADE PER DIN ISO 21940-11  
 G 6.3 / 3000 MIN<sup>-1</sup>  
 MASS  
 APPROX. 0.4 kg

PART	TYP	QUAN.	UT	MATERIAL NUMBER	DESCRIPTION	TECHNICAL SPECIFICATION	CUSTOMER NUMBER
-	OPT	1		31006800	SOCKET HEAD SCREW	MN692BL4-M10X30-12.9- IK	
2		1		10003660	SOCKET HEAD SCREW	ISO 4762-M10X30-12.9	
1		4		10018468	TORX-SCREW	MN659 M4X11-TX15-IP	

SCOPE OF DELIVERY INFORMATION		BOM INFORMATION		TIGHTENING TORQUE FOR MAPAL CLAMPING SCREWS	
INSERTS NOT INCLUDED		OPTIONAL PARTS (OPT) NOT INCLUDED SCOPE OF DELIVERY		PER MN678BL1	
MAPAL © FABRIK FUER PRAEZISIONSWERKZEUGE DR. KRESS KG		TITLE RADIAL MILLING PROGRAMME. BODY		DATE OF ISSUE	INDEX
ALL RIGHTS FOR THE INVENTIONS, KNOW-HOW, TECHNICAL SOLUTIONS AND DESIGNS SHOWN ON THE DRAWING ARE ENTITLED TO MAPAL ONLY. AS FAR AS MAPAL DID NOT REGISTER PROPERTY RIGHTS HEREUPON YET, MAPAL FORMALLY RESERVES THE RIGHT FOR THE REGISTRATION OF PROPERTY RIGHTS. THE DRAWING AS WELL AS THE MATTERS SHOWN ARE STRICTLY CONFIDENTIAL. REPRODUCTIONS MAY ONLY BE MADE FOR THE PURPOSE AGREED UPON. NEITHER THIS DRAWING NOR COPIES THEREOF MAY BE MADE ACCESSIBLE TO THIRD PARTIES. WITH THE DELIVERY OF THIS DRAWING NO RIGHT TO USE IT FOR ANY PURPOSE IS GRANTED. VIOLATIONS AGAINST THE OBLIGATIONS TO SECRECY AND USE RESTRICTIONS WILL BE PROSECUTED.		MAPAL Präzisionswerkzeuge Dr. Kress KG		DATE	INDEX
		GENERAL TOLERANCE ISO 2768-1H DIMENSIONS NOT SHOWN ARE MAPAL STANDARDS		SCALE	ORIGIN
				1:1	AAD
				TECHNICAL SPECIFICATION	SHEET
				ICM901-050-CA22-Z04R-SN_U12	1/1