



INDEX	CHANGES	DATE	NAME

NON TOLERANCED DIMENSIONS				
0.5	> 3	> 6	> 30	> 120
... 3	... 6	... 30	... 120	... 400
± 0.1	± 0.1	± 0.2	± 0.3	± 0.5
RADIOI, CHAMFERS				
± 0.2	± 0.5	± 1	± 1	± 1
ANGLES, DIM. OF THE SHORTER SIDE				
bis 10	> 10	> 50	> 120	> 400
... 50	... 120	... 400		
± 1°	± 30'	± 20'	± 10'	± 5'

-  OPTIMILL-3D-CR,Z=2
-  HP825

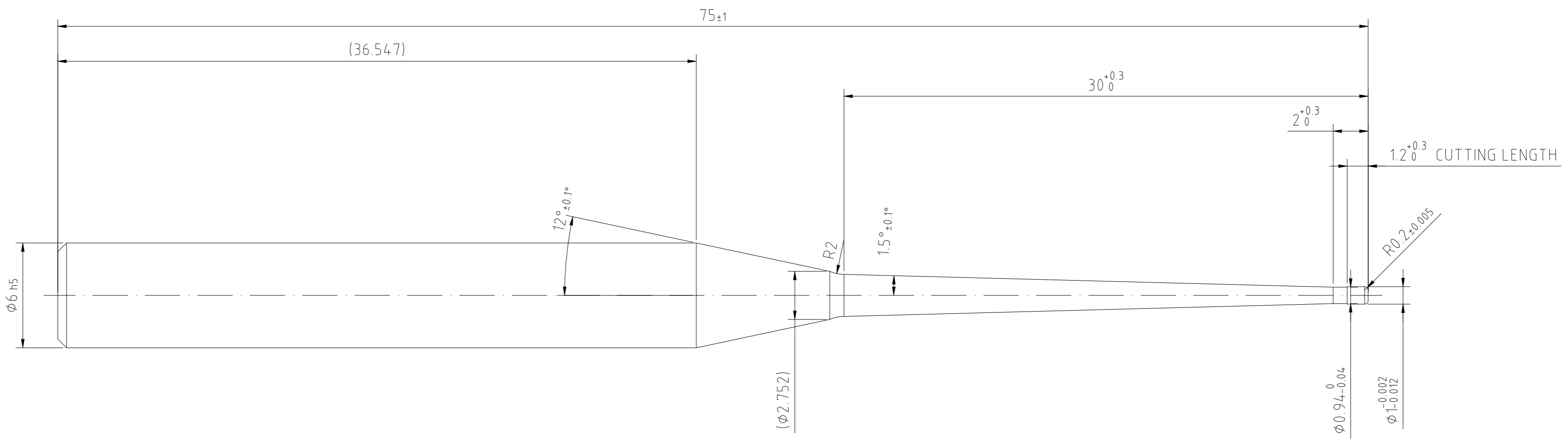

REGRINDING INFO	
TIP	<input type="radio"/>
OUTER DIAMETER	<input type="radio"/>
FLUTE	<input type="radio"/>
ADDING OF WORKING LENGTH	<input type="radio"/>
ADDING OF WORKING DIAMETER	<input type="radio"/>
DECOATING	<input type="radio"/>

● YES ● OPTIONAL ○ NO

MAPAL © FABRIK FUER PRAEZISIONSWERKZEUGE DR. KRESS KG <small>ALL RIGHTS FOR THE INVENTIONS, KNOW-HOW, TECHNICAL SOLUTIONS AND DESIGNS SHOWN ON THE DRAWING ARE ENTITLED TO MAPAL ONLY. AS FAR AS MAPAL DID NOT REGISTER PROPERTY RIGHTS HEREUPON YET, MAPAL FORMALLY RESERVES THE RIGHT FOR THE REGISTRATION OF PROPERTY RIGHTS. THE DRAWING AS WELL AS THE MATTERS SHOWN ARE STRICTLY CONFIDENTIAL. REPRODUCTIONS MAY ONLY BE MADE FOR THE PURPOSE AGREED UPON. NEITHER THIS DRAWING NOR COPIES THEREOF MAY BE MADE ACCESSIBLE TO THIRD PARTIES. WITH THE DELIVERY OF THIS DRAWING NO RIGHT TO USE IT FOR ANY PURPOSE IS GRANTED. VIOLATIONS AGAINST THE OBLIGATIONS TO SECRECY AND USE RESTRICTIONS WILL BE PROSECUTED.</small>	TITLE OPTIMILL-3D-CR, SHANKFORM HA, SC, COATED		DATE OF ISSUE 2021-11-25	CREATED MF	DOCUMENT 6074.08618-000-02-ED1	INDEX 00
	GENERAL TOLERANCE ISO 2768-mH SIZE ISO 14.405-1	DIMENSIONS NOT SHOWN ARE MAPAL STANDARDS	SCALE 5:1	TECHNICAL SPECIFICATION MCR102-010-0020-3000C075-HP825	ORIGIN AAD	SHEET 1/1