

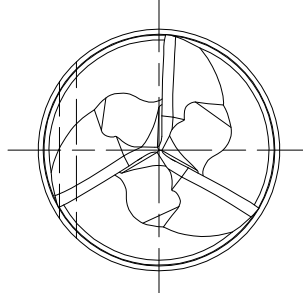
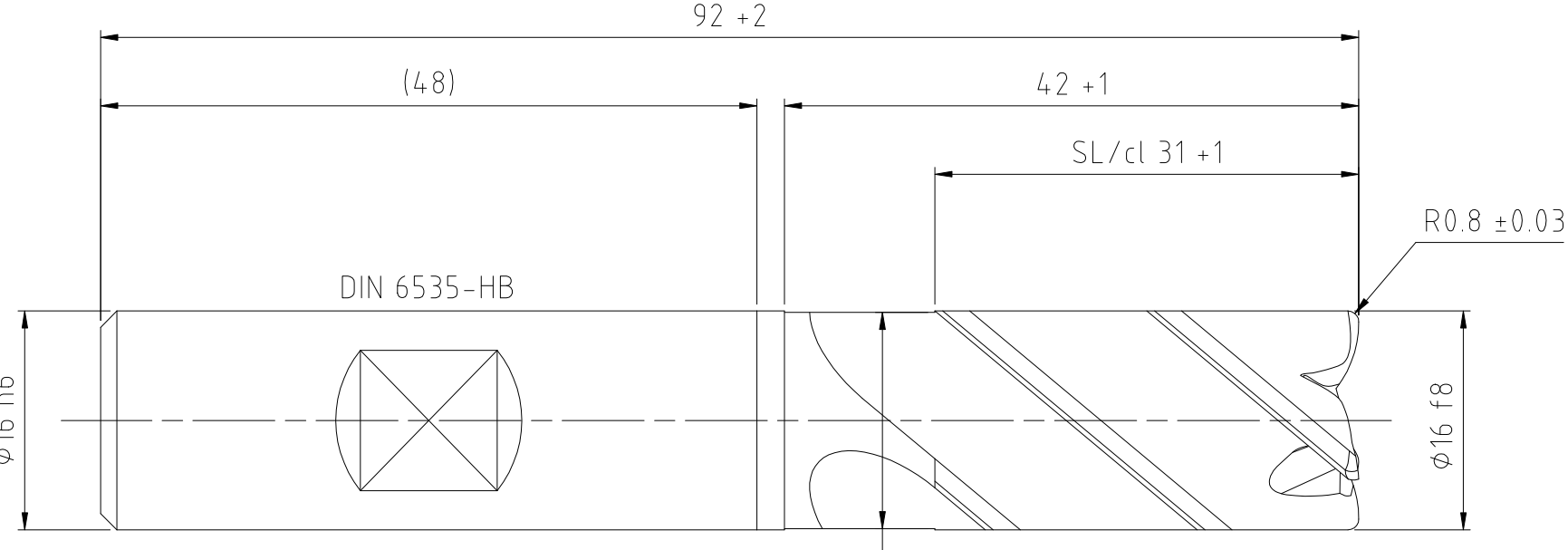

1	2	3	4	5	6	7	8		
MACH.NO.:		STATION:	SPINDLE:		INDEX NO.	CHANGES	DATE	NAME	
PART-NAME.:							-	-	-
PART NO.:							-	-	-
MATERIAL:							-	-	-
OP-NO.:		TOOL-NO.:	HOLE-NO.:						
SCHNEIDENZAHL : 3 / rechts SPANNUT. : ~42° / rechts SCHNEIDSTOFF : HP920 GEEIGNETE WERKSTOFFE . : SIEHE KATALOG FEHLENDE ANGABEN NACH ERFAHRUNG DES HERSTELLERS			CUTTING EDGES. : 3 / right CHIP FLUTES : ~42° / right CUTTING MATERIAL. : HP920 SUITABLE MATERIALS: SEE CATALOG MISSING SPECIFICATIONS ACCORING TO EXPERIENCE OF MANUFACTURER.						
									
OPTIMILL-UNI-HPC-POCKET OHNE IK/WITHOUT I.C.			DIN 6535-HB						
BALANCING GRADE DIN ISO 1940-G (COMPLETE ASSEMBLY) AT R.P.M. -1			THIS DRAWING REMAINS OUR EXCLUSIVE PROPERTY. IT IS ENTRUSTED ONLY FOR THE PURPOSE AGREED UPON AND MAY NOT BE USED FOR ANY OTHER PURPOSE. COPIES OR OTHER REPRODUCTIONS MAY ONLY BE MADE FOR THE PURPOSE AGREED UPON. NEITHER ORIGINALS NOR REPRODUCTIONS MAY BE TRANSMITTED OR OTHER- WISE MADE ACCESSIBLE TO A THIRD PARTY WITHOUT OUR WRITTEN CONSENT.				DATE	NAME	
ADDITIONALLY TO VA-NO: 07.05.01 MARK WITH ---			DIMENSIONAL TOLERANCES PER ISO 2768-M UNLESS OTHERWISE SPECIFIED		DIMENSIONS NOT SHOWN ARE MAPAL STANDARD		DRAWN 04.04.17 APP. 04.04.17 CHK.	ms DKO	
			TITLE: OPTIMILL-UNI-HPC-POCKET, HB, VHM, BESCHICHTET / HB, SC, COATED				SCALE: 2:1 FORMAT: A3		
			TECHNICAL SPECIFICATION SCM810-1600Z03R-R0080-HB-HP920		MATERIAL NUMBER.: 30788038		DRAWING NO.: 606862743-000-00-ED1		
			REPLACES DWG. NO.:		REPLACED BY DWG. NO.:		SHEET 1 V.1 SHEETS		
CUST.:		SIMILAR:		BARCODE-ZONE					
JOB-NO.:			PROJECT-NO.:			SKETCH:			