

CLAMPING	SPARE PARTS	ALLOCATION OF PARTS	INDEX	CHANGES	DATE	NAME
		DIAMETER				
-	1	40				
-	-	-				
-	-	-				
-	-	-				
-	-	-				

DIN 1835 - B 32

UNEQUAL POSITIONING

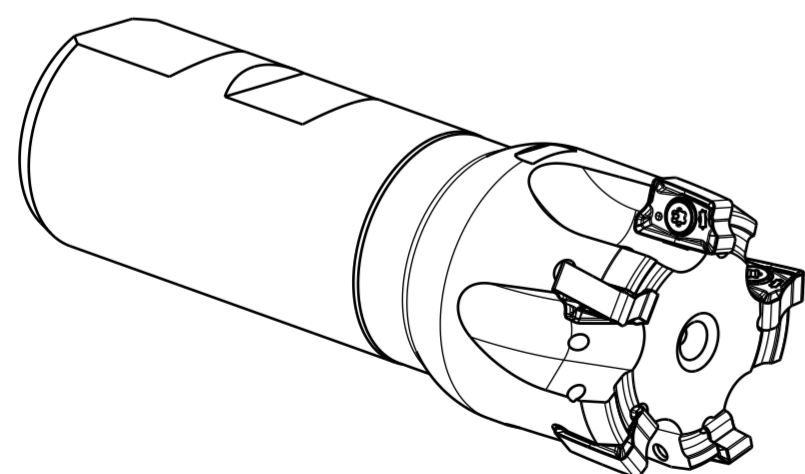
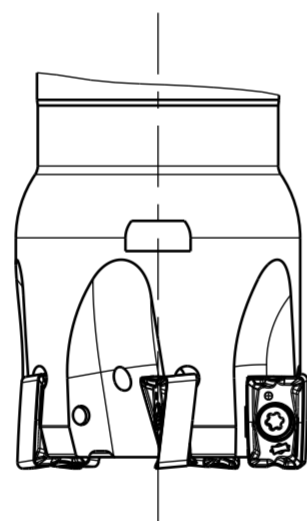
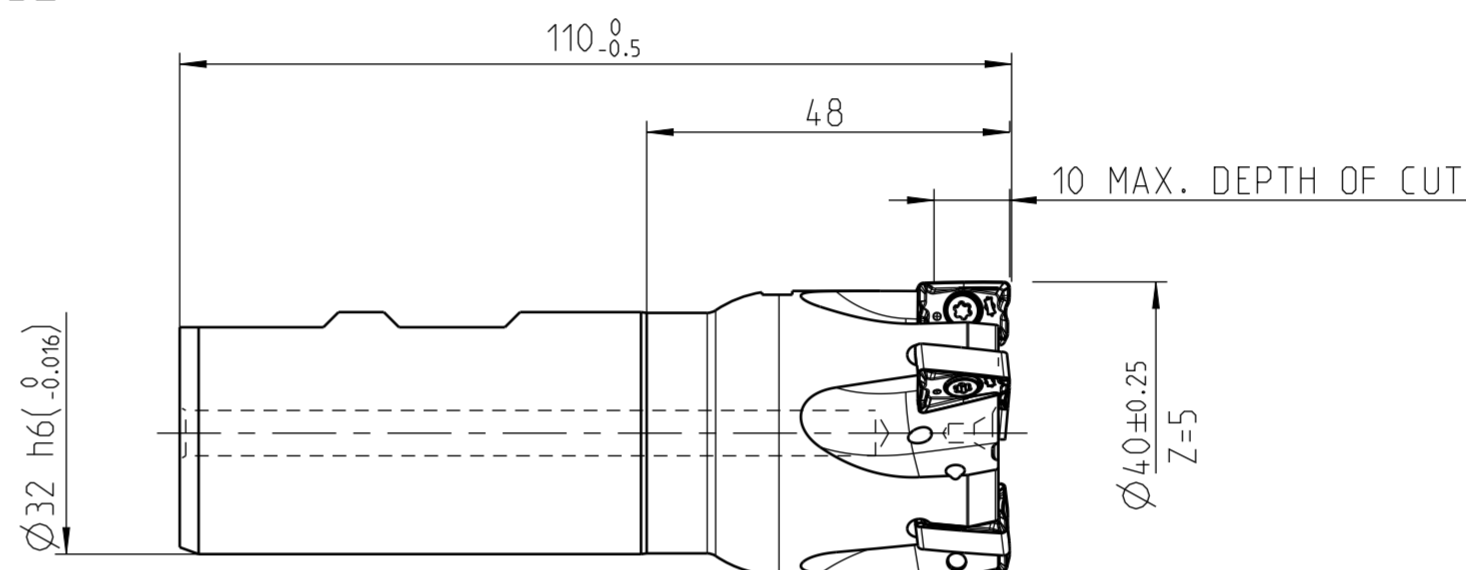
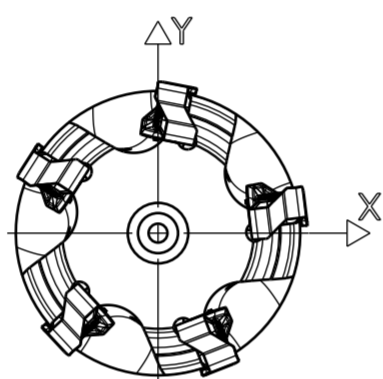

1	5	10105076	TORX-SCREW	MN659 M3X8.5-TX8-IP				
PART	TYP	QUAN.	UT	MATERIAL NUMBER	DESCRIPTION	TECHNICAL SPECIFICATION	CUSTOMER NUMBER	
SCOPE OF DELIVERY INFORMATION				TIGHTENING TORQUE FOR MAPAL CLAMPING SCREWS				
INSERTS NOT INCLUDED				PER MN678BL1				
MAPAL © FABRIK FUER PRAEZISIONSWERKZEUGE DR. KRESS KG			TITLE RADIAL MILLING PROGRAMME. BODY			FORMAT A2		
<small>ALL RIGHTS FOR THE INVENTIONS, KNOW-HOW, TECHNICAL SOLUTIONS AND DESIGNS SHOWN ON THE DRAWING ARE ENTITLED TO MAPAL ONLY. AS FAR AS MAPAL DID NOT REGISTER PROPERTY RIGHTS HEREUPON YET, MAPAL FORMALLY RESERVES THE RIGHT FOR THE REGISTRATION OF PROPERTY RIGHTS. THE DRAWING AS WELL AS THE MATTERS SHOWN ARE STRICTLY CONFIDENTIAL. REPRODUCTIONS MAY ONLY BE MADE FOR THE PURPOSE AGREED UPON. NEITHER THIS DRAWING NOR COPIES THEREOF MAY BE MADE ACCESSIBLE TO THIRD PARTIES. WITH THE DELIVERY OF THIS DRAWING NO RIGHT TO USE IT FOR ANY PURPOSE IS GRANTED. VIOLATIONS AGAINST THE OBLIGATIONS TO SECRECY AND USE RESTRICTIONS WILL BE PROSECUTED.</small>			MAPAL Präzisionswerkzeuge Dr. Kress KG		DATE OF ISSUE 2018-05-29	INDEX 00		
			DATE	APPROVED	DOCUMENT 607040941-000-01-ED1	ORIGIN AAD		
BALANCE GRADE PER DIN ISO 21940-11 G 6.3 / 3000 MIN ⁻¹ MASS APPROX. 0.7 kg			GENERAL TOLERANCE ISO 2768-1H SIZE ISO 14405-1Ⓢ		DIMENSIONS NOT SHOWN ARE MAPAL STANDARDS	SCALE 1:1	TECHNICAL SPECIFICATION ICM901-040-HB32-Z05R-AN_U12	SHEET 1/1