

CLAMPING	SPARE PARTS	ALLOCATION OF PARTS	INDEX	CHANGES	DATE	NAME
		DIAMETER				
-	1	80				
-	-	-				
-	-	-				
-	-	-				
-	-	-				

UNEQUAL POSITIONING

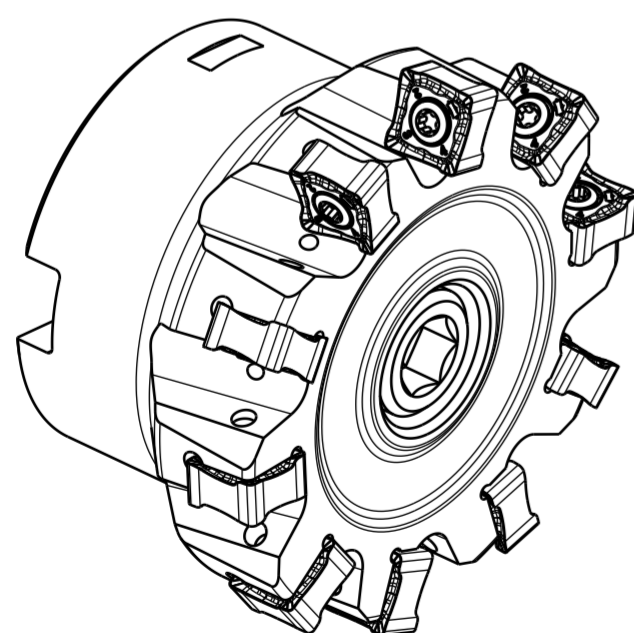
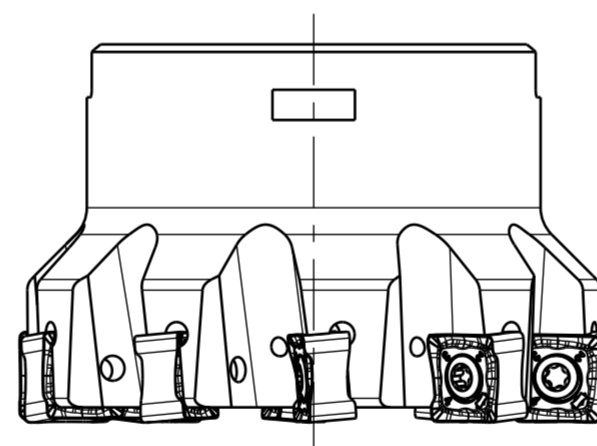
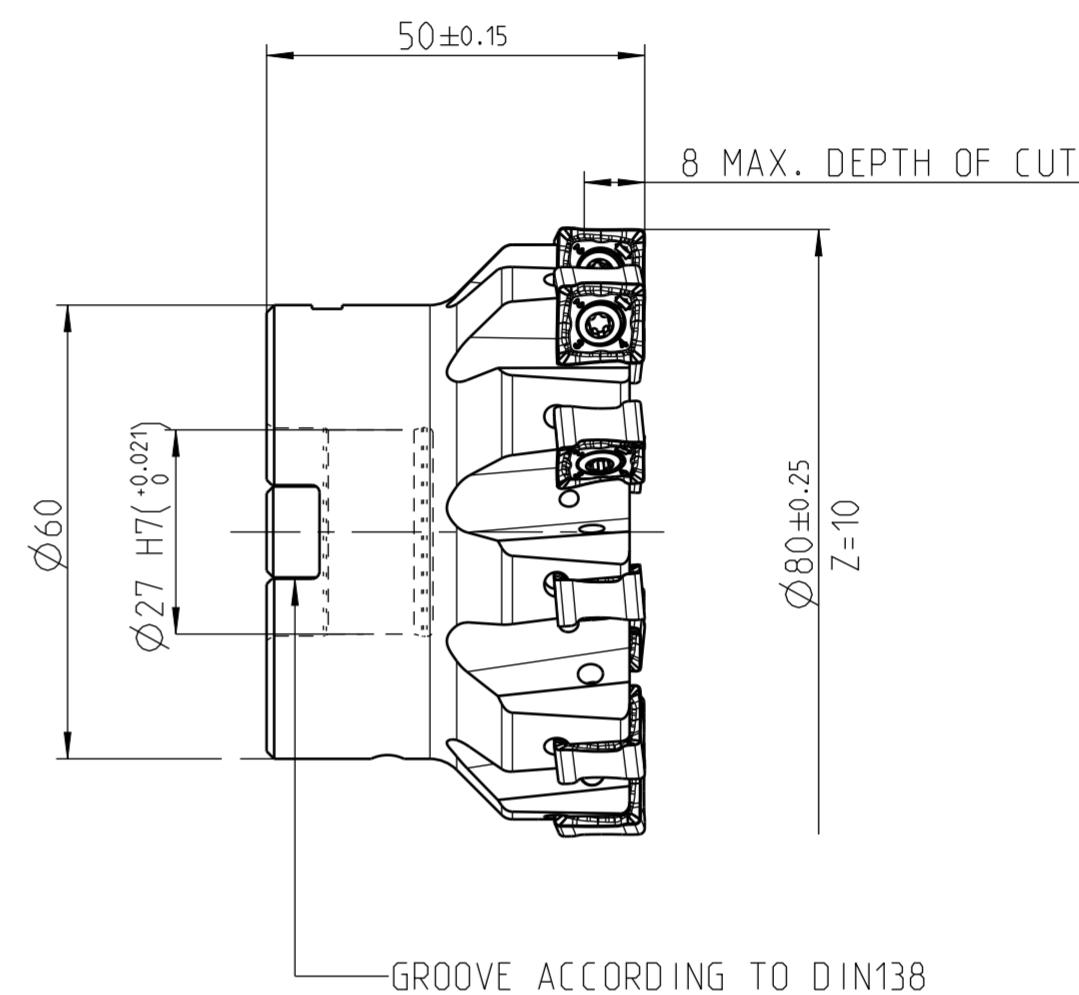
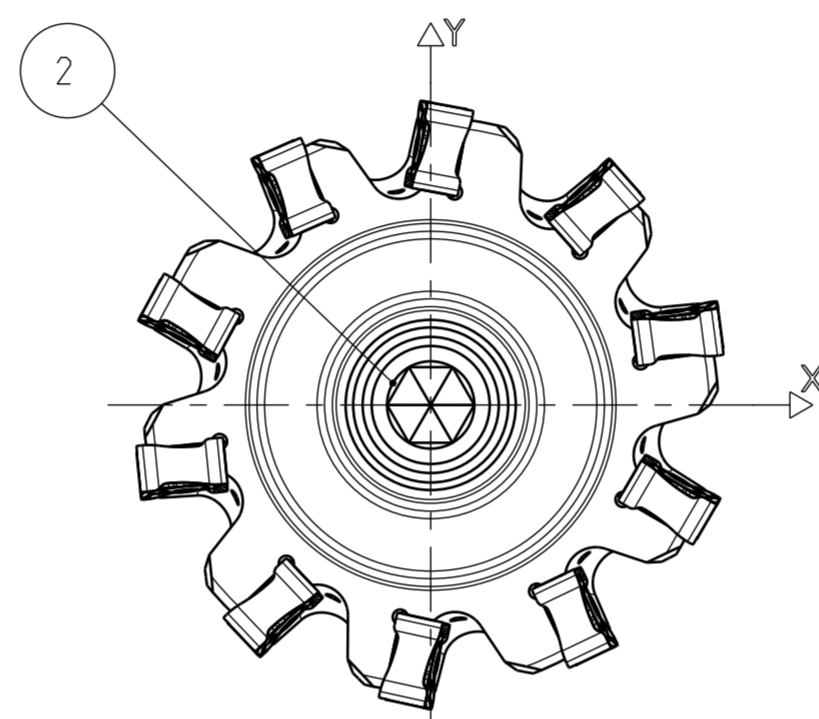

PART	TYP	QUAN.	UT	MATERIAL NUMBER	DESCRIPTION	TECHNICAL SPECIFICATION	CUSTOMER NUMBER
-	OPT	1		31008546	SOCKET HEAD SCREW	MN692BL4-M12X35-12.9-1K	
2		1		10003677	SOCKET HEAD SCREW	ISO 4762-M12X35-12.9	
1		10		10018468	TORX-SCREW	MN659 M4X11-TX15-IP	

SCOPE OF DELIVERY INFORMATION INSERTS NOT INCLUDED	BOM INFORMATION OPTIONAL PARTS (OPT) NOT INCLUDED SCOPE OF DELIVERY	TIGHTENING TORQUE FOR MAPAL CLAMPING SCREWS PER MN678BL1
---	--	---

MAPAL © FABRIK FUER PRAEZISIONSWERKZEUGE DR. KRESS KG	TITLE RADIAL MILLING PROGRAMME. BODY	DATE OF ISSUE 2018-11-13	CREATED KLA	DOCUMENT 607041016-000-01-ED1	INDEX 00
ALL RIGHTS FOR THE INVENTIONS, KNOW-HOW, TECHNICAL SOLUTIONS AND DESIGNS SHOWN ON THE DRAWING ARE ENTITLED TO MAPAL ONLY. AS FAR AS MAPAL DID NOT REGISTER PROPERTY RIGHTS HEREUPON YET, MAPAL FORMALY RESERVES THE RIGHT FOR THE REGISTRATION OF PROPERTY RIGHTS. THE DRAWING AS WELL AS THE MATTERS SHOWN ARE STRICTLY CONFIDENTIAL. REPRODUCTIONS MAY ONLY BE MADE FOR THE PURPOSE AGREED UPON. NEITHER THIS DRAWING NOR COPIES THEREOF MAY BE MADE ACCESSIBLE TO THIRD PARTIES. WITH THE DELIVERY OF THIS DRAWING NO RIGHT TO USE IT FOR ANY PURPOSE IS GRANTED. VIOLATIONS AGAINST THE OBLIGATIONS TO SECRECY AND USE RESTRICTIONS WILL BE PROSECUTED.	GENERAL TOLERANCE ISO 2768-1H SIZE ISO 14405-1Ⓢ	DIMENSIONS NOT SHOWN ARE MAPAL STANDARDS	DATE 2018-11-13	APPROVED KLA	MATERIAL NUMBER 31002281
BALANCE GRADE PER DIN ISO 21940-11 G 6.3 / 3000 MIN ⁻¹	MASS APPROX. 1.1 kg	SCALE 1:1	TECHNICAL SPECIFICATION ICM901-080-CA27-Z10R-SN_U12		SHEET 1/1

BALANCE GRADE PER DIN ISO 21940-11
G 6.3 / 3000 MIN⁻¹
MASS
APPROX. 1.1 kg