

CLAMPING	SPARE PARTS	ALLOCATION OF PARTS	INDEX	CHANGES	DATE	NAME
		DIAMETER				
-	1	40				
-	-	-				
-	-	-				
-	-	-				
-	-	-				

DIN 1835 - B 32

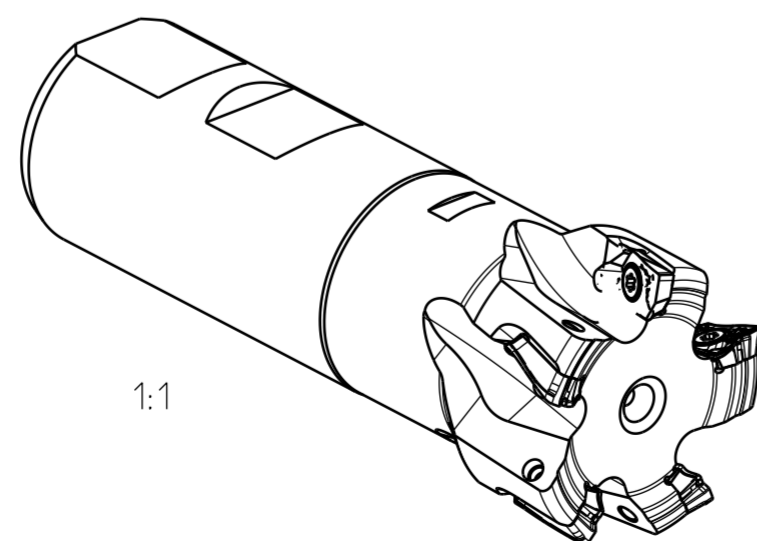
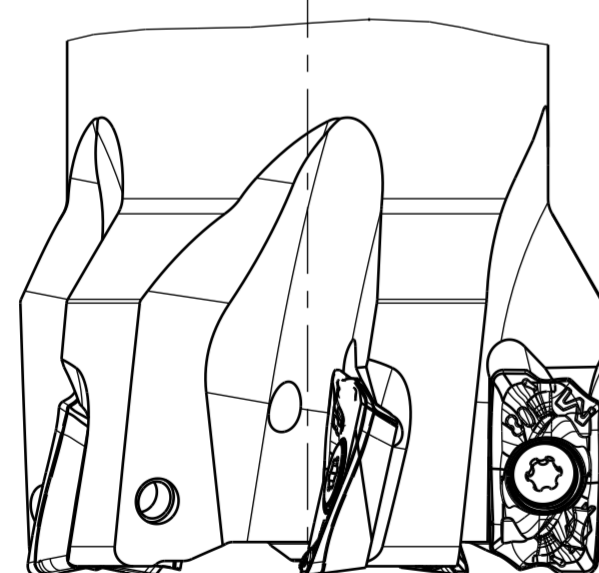
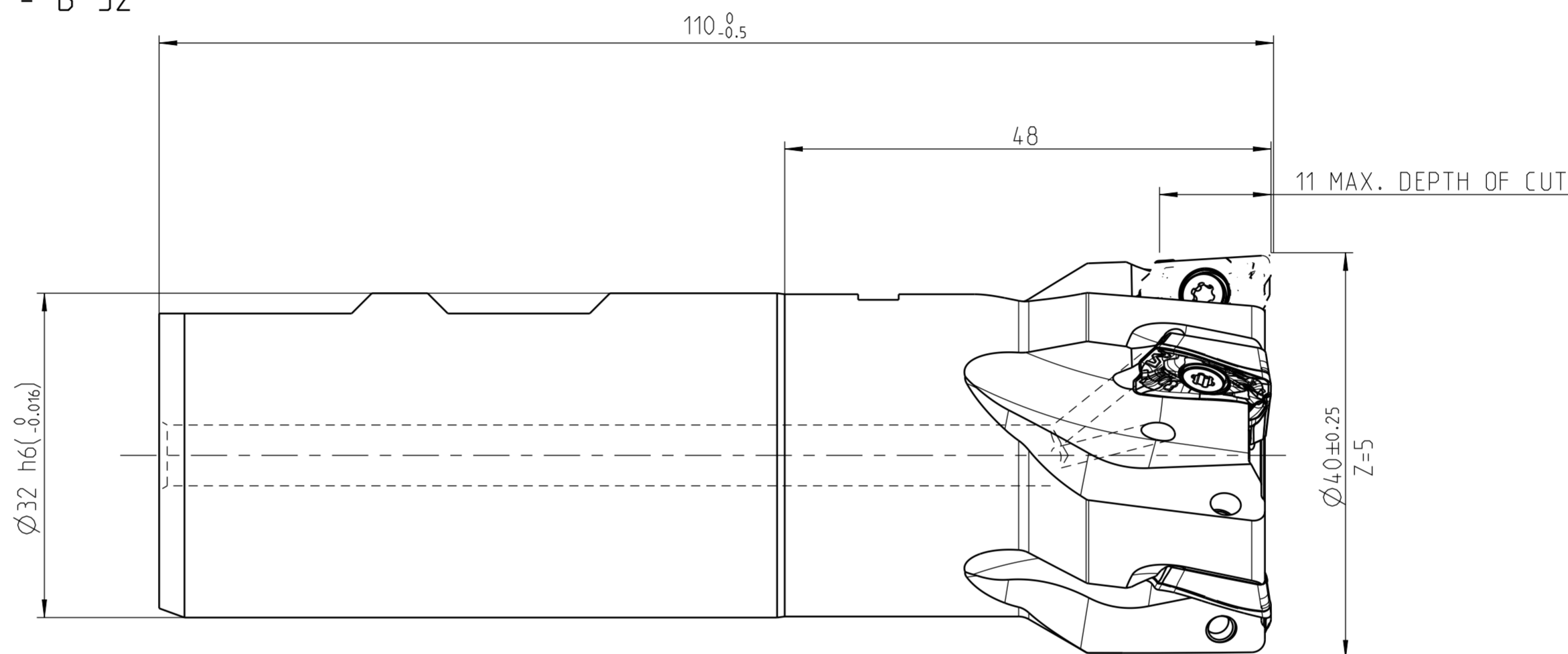
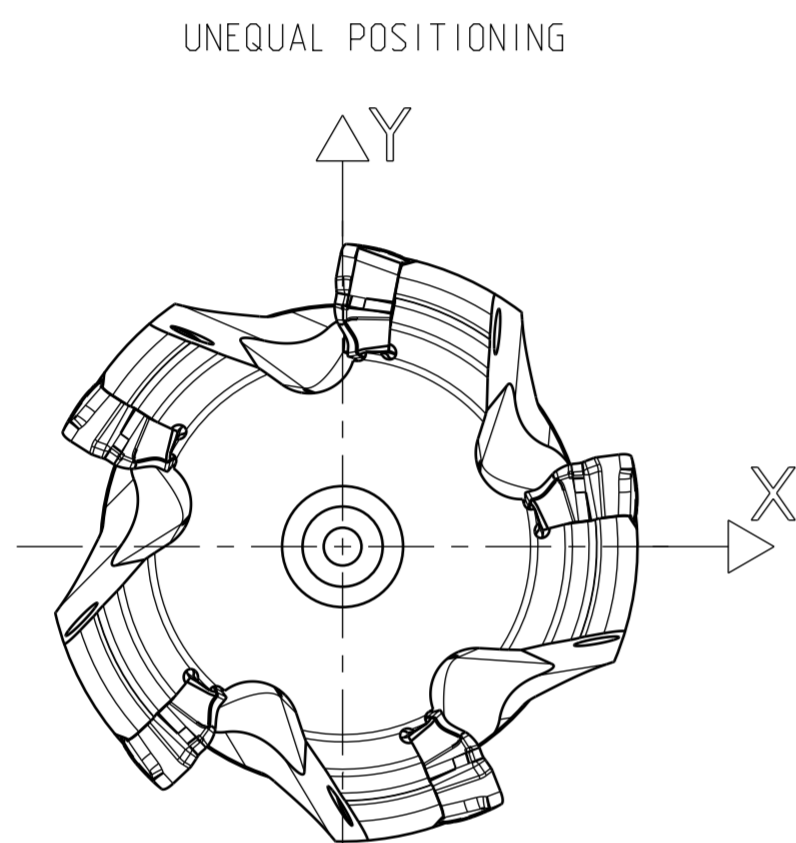

BALANCE GRADE PER DIN ISO 21940-11
 G 6.3 / 3000 MIN⁻¹
 MASS
 APPROX. 0.6 kg

1	5	10105074	TORX-SCREW	MN659 M3X6-TX8-IP		
PART TYP	QUAN.	UT	MATERIAL NUMBER	DESCRIPTION	TECHNICAL SPECIFICATION	CUSTOMER NUMBER
SCOPE OF DELIVERY INFORMATION				TIGHTENING TORQUE FOR MAPAL CLAMPING SCREWS		
INSERTS NOT INCLUDED				PER MN678BL1		
MAPAL © FABRIK FUER PRAEZISIONSWERKZEUGE DR. KRESS KG			TITLE RADIAL MILLING PROGRAMME. BODY		FORMAT A2	
ALL RIGHTS FOR THE INVENTIONS, KNOW-HOW, TECHNICAL SOLUTIONS AND DESIGNS SHOWN ON THE DRAWING ARE ENTITLED TO MAPAL ONLY. AS FAR AS MAPAL DID NOT REGISTER PROPERTY RIGHTS HEREUPON YET, MAPAL FORMALLY RESERVES THE RIGHT FOR THE REGISTRATION OF PROPERTY RIGHTS. THE DRAWING AS WELL AS THE MATTERS SHOWN ARE STRICTLY CONFIDENTIAL. REPRODUCTIONS MAY ONLY BE MADE FOR THE PURPOSE AGREED UPON. NEITHER THIS DRAWING NOR COPIES THEREOF MAY BE MADE ACCESSIBLE TO THIRD PARTIES. WITH THE DELIVERY OF THIS DRAWING NO RIGHT TO USE IT FOR ANY PURPOSE IS GRANTED. VIOLATIONS AGAINST THE OBLIGATIONS TO SECRECY AND USE RESTRICTIONS WILL BE PROSECUTED.			MAPAL Präzisionswerkzeuge Dr. Kress KG		DATE OF ISSUE 2019-08-09 CREATED ANS DOCUMENT 607040909-000-01-ED1 MATERIAL NUMBER 31002175	INDEX 00 ORIGIN AAD
			GENERAL TOLERANCE ISO 2768-1H SIZE ISO 14405-1Ⓢ	DIMENSIONS NOT SHOWN ARE MAPAL STANDARDS	SCALE 2:1 TECHNICAL SPECIFICATION ICM901-040-HB32-Z05R-A0_T12	SHEET 1/1