



INDEX	CHANGES	DATE	NAME

NON TOLERANCED DIMENSIONS				
0.5	> 3	> 6	> 30	> 120
... 3	... 6	... 30	... 120	... 400
± 0.1	± 0.1	± 0.2	± 0.3	± 0.5
± 0.2	± 0.5	± 1	± 1	± 1
RADII, CHAMFERS				
± 0.2	± 0.5	± 1	± 1	± 1
ANGLES, DIM. OF THE SHORTER SIDE				
bis 10	> 10	> 50	> 120	> 400
... 50	... 120	... 400		
± 1°	± 30'	± 20'	± 10'	± 5'

 OPTIMILL-3D-CR-GRAPHITE, Z=3
 HC116

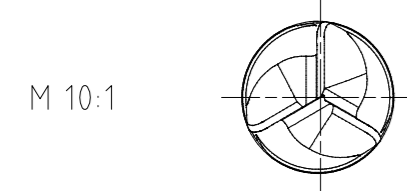
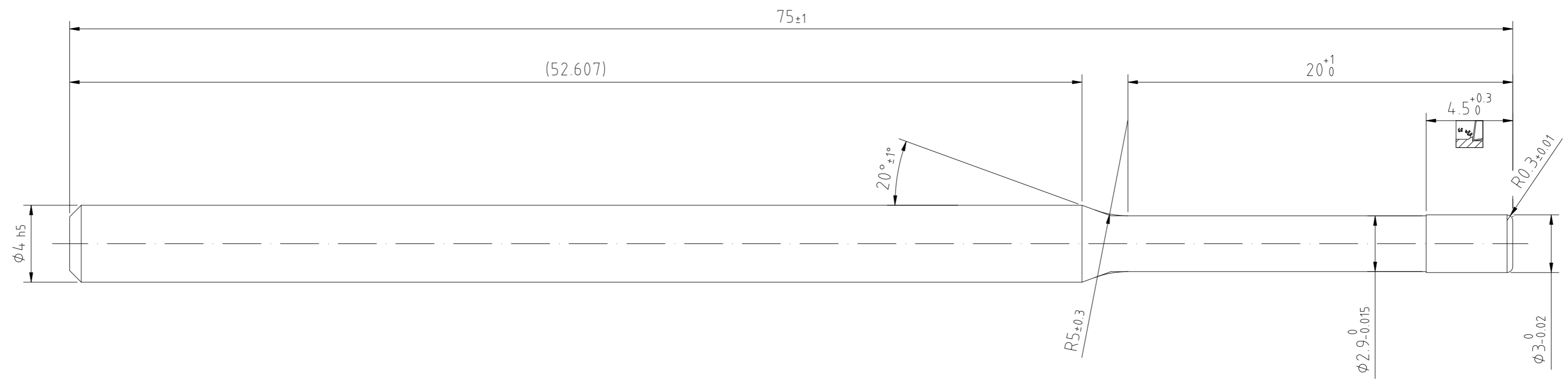

REGRINDING INFO	
TIP	<input type="radio"/>
OUTER DIAMETER	<input type="radio"/>
FLUTE	<input type="radio"/>
ADDING OF WORKING LENGTH	<input type="radio"/>
ADDING OF WORKING DIAMETER	<input type="radio"/>
DECOATING	<input type="radio"/>

YES
 OPTIONAL
 NO

PART	TYP	QUANT.	UT	MATERIAL NUMBER	DESCRIPTION	TECHNICAL SPECIFICATION	CUSTOMER MATERIAL NUMBER
1	1	PC	31155059	OPTIMILL-3D-CR-GRAPHITE, SHANKFORM HA, COATED	TCR113-030-0030-2000X075-HC116		
MAPAL © FABRIK FUER PRAEZISIONSWERKZEUGE DR. KRESS KG					TITLE OPTIMILL-3D-CR-GRAPHITE, SHANKFORM HA, COATED		FORMAT A2
ALL RIGHTS FOR THE INVENTIONS, KNOW-HOW, TECHNICAL SOLUTIONS AND DESIGNS SHOWN ON THE DRAWING ARE ENTITLED TO MAPAL ONLY. AS FAR AS MAPAL DID NOT REGISTER PROPERTY RIGHTS HEREUPON YET, MAPAL FORMALLY RESERVES THE RIGHT FOR THE REGISTRATION OF PROPERTY RIGHTS. THE DRAWING AS WELL AS THE MATTERS SHOWN ARE STRICTLY CONFIDENTIAL. REPRODUCTIONS MAY ONLY BE MADE FOR THE PURPOSE AGREED UPON. NEITHER THIS DRAWING NOR COPIES THEREOF MAY BE MADE ACCESSIBLE TO THIRD PARTIES. WITH THE DELIVERY OF THIS DRAWING NO RIGHT TO USE IT FOR ANY PURPOSE IS GRANTED. VIOLATIONS AGAINST THE OBLIGATIONS TO SECRECY AND USE RESTRICTIONS WILL BE PROSECUTED.					MAPAL Präzisionswerkzeuge Dr. Kress KG		DATE OF ISSUE 2025-02-05
GENERAL TOLERANCE ISO 2768-mH SIZE ISO 14405-1					DIMENSIONS NOT SHOWN ARE MAPAL STANDARDS		CREATED JG
					SCALE 5:1		DOCUMENT 608198095-000-00-ED1
DATE 2025-02-05					APPROVED		MATERIAL NUMBER 31152960
TECHNICAL SPECIFICATION MCR113-030-0030-2000X075-HC116					SHEET 1/1		