

INDEX	CHANGES	DATE	NAME
1	SINTERED CLAMPING GROOVE NEW ADDED: PER ECN FROM 1997-09-18 MR. STEIDLE	1997-10-15	BO
2	PCD-BLANK AND CARBIDE-BLANK OPTIMISED: PER ECN FROM 2020-06-01 DR. FRITZ	2012-03-02	MUS
3	PCD-BLANK AND CARBIDE-BLANK OPTIMISED: PER ECN FROM 2021-04-23 MR. THOMAS KERN	2021-04-29	BUK

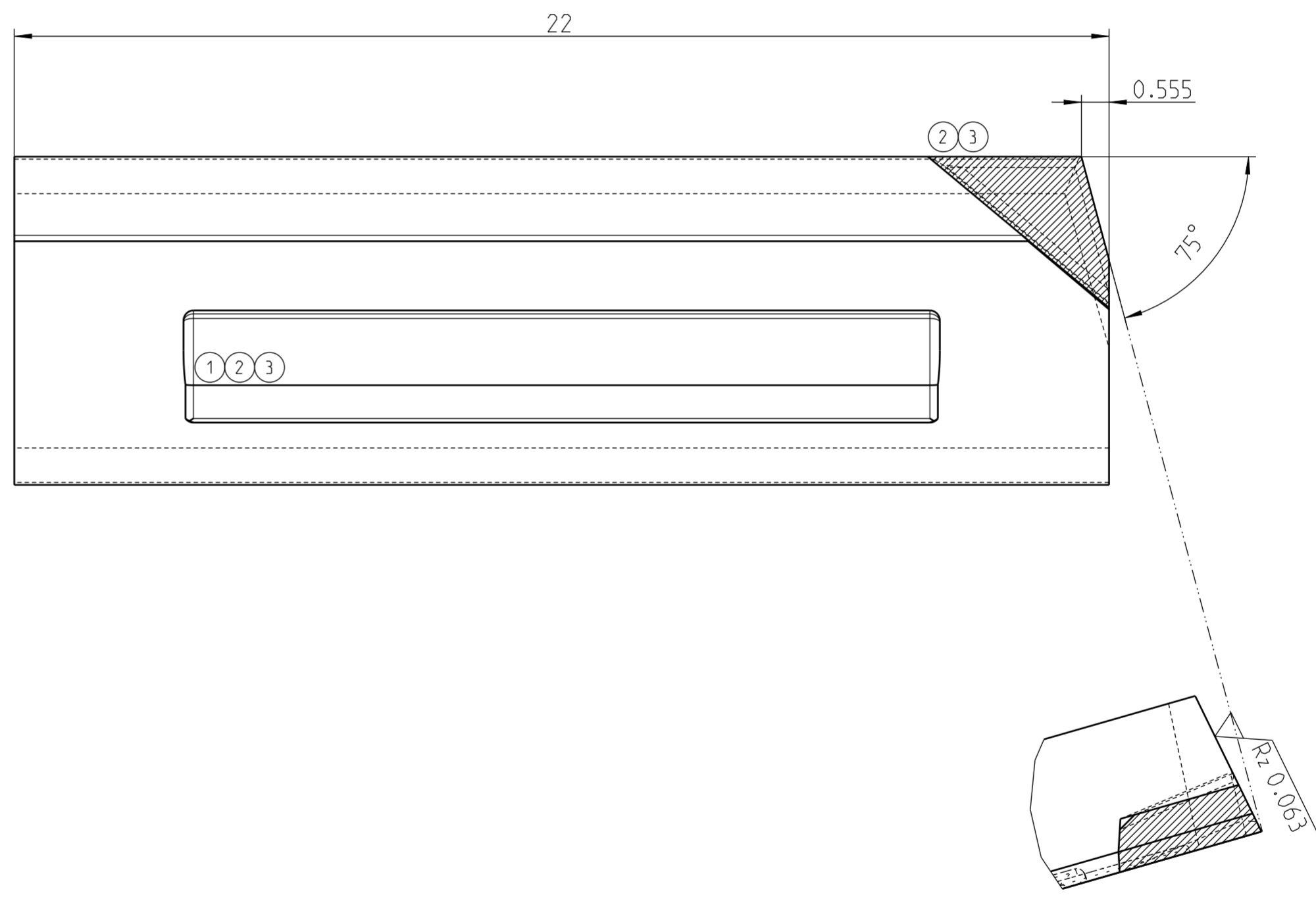
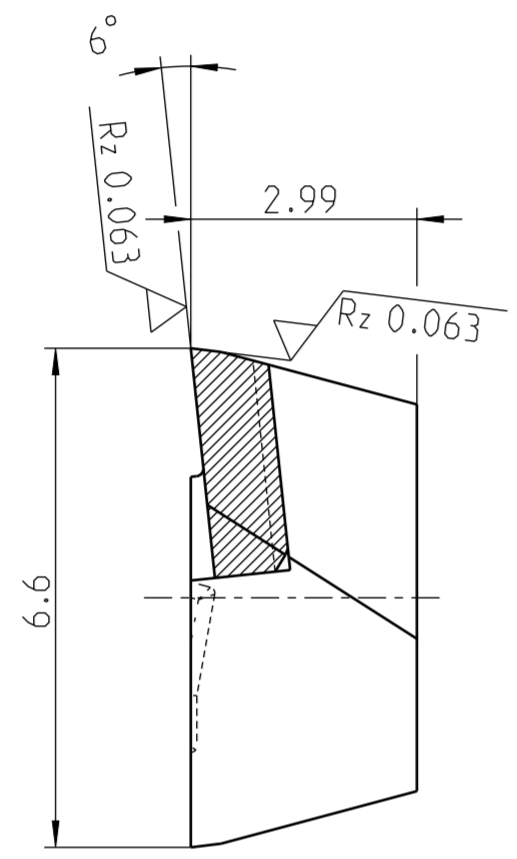

$\sqrt{Rz 1}$ ($\sqrt{Rz 0.063}$)

MAPAL © FABRIK FUER PRAEZISIONSWERKZEUGE DR. KRESS KG <small>ALL RIGHTS FOR THE INVENTIONS, KNOW-HOW, TECHNICAL SOLUTIONS AND DESIGNS SHOWN ON THE DRAWING ARE ENTITLED TO MAPAL ONLY. AS FAR AS MAPAL DID NOT REGISTER PROPERTY RIGHTS HEREUPON YET, MAPAL FORMALLY RESERVES THE RIGHT FOR THE REGISTRATION OF PROPERTY RIGHTS. THE DRAWING AS WELL AS THE MATTERS SHOWN ARE STRICTLY CONFIDENTIAL. REPRODUCTIONS MAY ONLY BE MADE FOR THE PURPOSE AGREED UPON. NEITHER THIS DRAWING NOR COPIES THEREOF MAY BE MADE ACCESSIBLE TO THIRD PARTIES. WITH THE DELIVERY OF THIS DRAWING NO RIGHT TO USE IT FOR ANY PURPOSE IS GRANTED. VIOLATIONS AGAINST THE OBLIGATIONS TO SECRECY AND USE RESTRICTIONS WILL BE PROSECUTED.</small>	TITLE MAPAL-BLADE, PCD TIPPED		DATE OF ISSUE 1982-12-10	CREATED AP	DOCUMENT 607551188-000-00-ED1	INDEX 3
	GENERAL TOLERANCE ISO 2768-1H SIZE ISO 14405-1 ©	DIMENSIONS NOT SHOWN ARE MAPAL STANDARDS		SCALE 10:1	MATERIAL NUMBER 30669502	TECHNICAL SPECIFICATION SZ93R6-PU620
						SHEET 1/1