



OPTIMILL-UNI-HPC-POCKET Z3

42° HELICAL FLUTET AT Ø5.00

CUT
MAT

HP920

MAT

P/M/K

REGRINDING INFO	
TIP	NO
OUTER DIAMETER [D1]	NO
FLUTE	NO
NECK LENGTH [L3]	NO
NECK DIAMETER [D3]	NO
DECOATING	NO

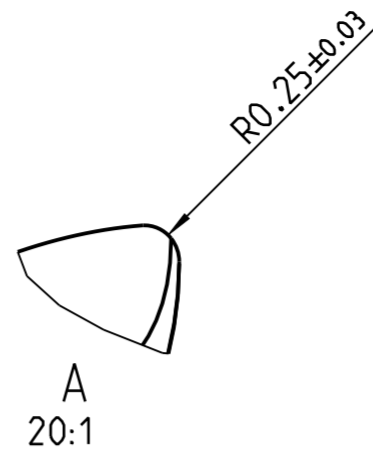

INDEX	CHANGES	DATE	NAME

NON TOLERANCED DIMENSIONS					
0.5	> 3	> 6	> 30	> 120	> 400
...3	...6	...30	...120	...400	...1000
± 0.1	± 0.1	± 0.2	± 0.3	± 0.5	± 0.8
RADII, CHAMFERS					
± 0.2	± 0.5	± 1	± 1	± 1	± 1
ANGLES, DIM. OF THE SHORTER SIDE					
bis 10	> 10	> 50	> 120	> 400	> 400
...50	...120	...400	...400		
± 1°	± 30'	± 20'	± 10'	± 5'	

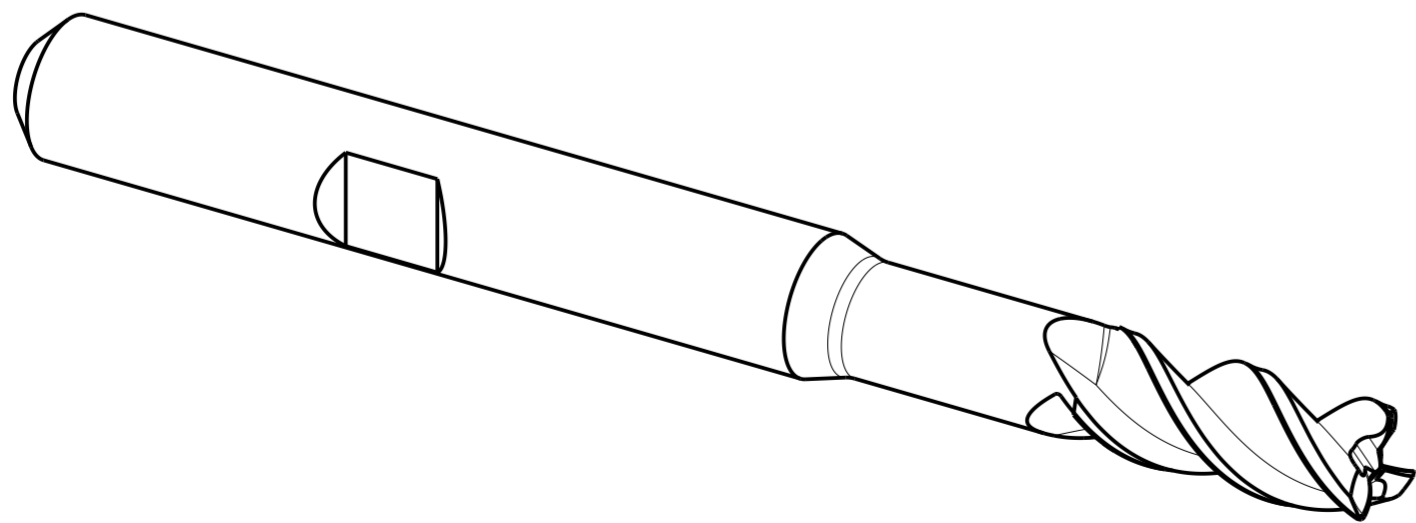
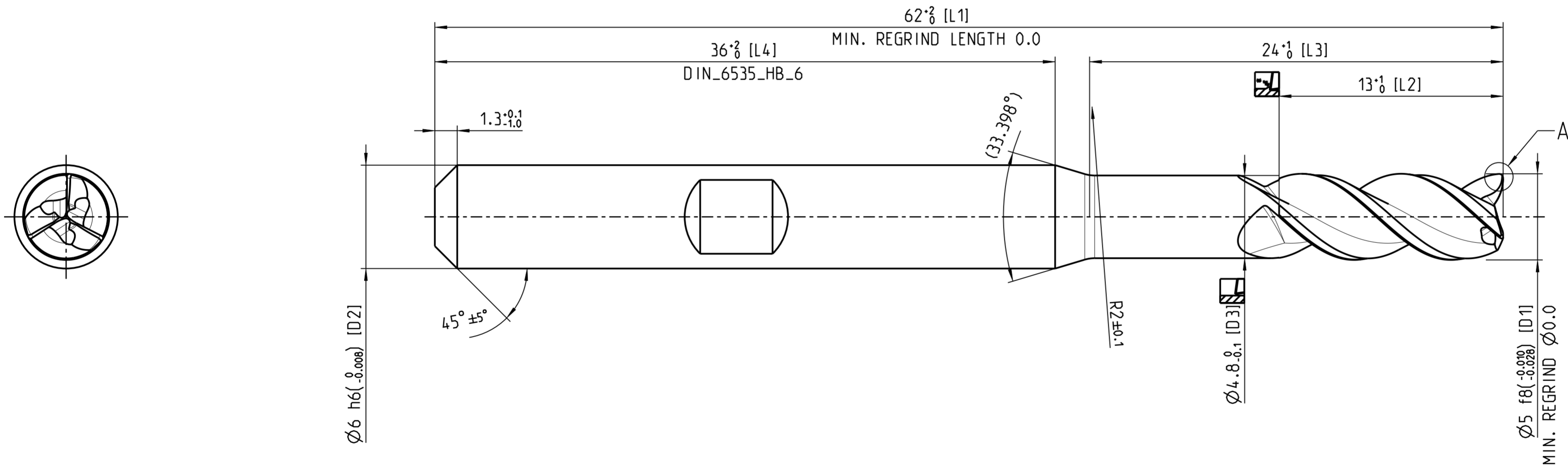

MASS
APPROX. 0.010 kg

MAPAL © FABRIK FUER PRAEZISIONSWERKZEUGE DR. KRESS KG <small>ALL RIGHTS FOR THE INVENTIONS, KNOW-HOW, TECHNICAL SOLUTIONS AND DESIGNS SHOWN ON THE DRAWING ARE ENTITLED TO MAPAL ONLY. AS FAR AS MAPAL DID NOT REGISTER PROPERTY RIGHTS HEREUPON YET, MAPAL FORMALLY RESERVES THE RIGHT FOR THE REGISTRATION OF PROPERTY RIGHTS. THE DRAWING AS WELL AS THE MATTERS SHOWN ARE STRICTLY CONFIDENTIAL. REPRODUCTIONS MAY ONLY BE MADE FOR THE PURPOSE AGREED UPON. NEITHER THIS DRAWING NOR COPIES THEREOF MAY BE MADE ACCESSIBLE TO THIRD PARTIES. WITH THE DELIVERY OF THIS DRAWING NO RIGHT TO USE IT FOR ANY PURPOSE IS GRANTED. VIOLATIONS AGAINST THE OBLIGATIONS TO SECURE AND USE RESTRICTIONS WILL BE PROSECUTED.</small>		TITLE OPTIMILL-UNI-HPC-POCKET, SHANKFORM HB, COATED			FORMAT A2
MAPAL Präzisionswerkzeuge Dr. Kress KG	DATE OF ISSUE 2025-02-25	CREATED DESIGN A.	DOCUMENT 607423148-000-00-ED1		INDEX 00
	DATE	APPROVED	MATERIAL NUMBER 31031146		ORIGIN ALD
GENERAL TOLERANCE ISO 2768-mH SIZE ISO 14405-1	DIMENSIONS NOT SHOWN ARE MAPAL STANDARDS	SCALE 5:1	TECHNICAL SPECIFICATION SCM800-0500Z03R-R0025HB-HP920		
SHEET 1/1		SHEET 1/1			