

A

B

C

D

E

F

G

H

INDEX	CHANGES	DATE	NAME

DEBTOR NAME/CUSTOMER NAME: MAPAL DR. KRESS KG  
 DEBTOR/CUSTOMER NO.: 400013  
 SIMILAR  
 SKETCH  
 DESIGN ORDER NO.: 2100076659  
 QUOTE: XPKT-FRAESER ST

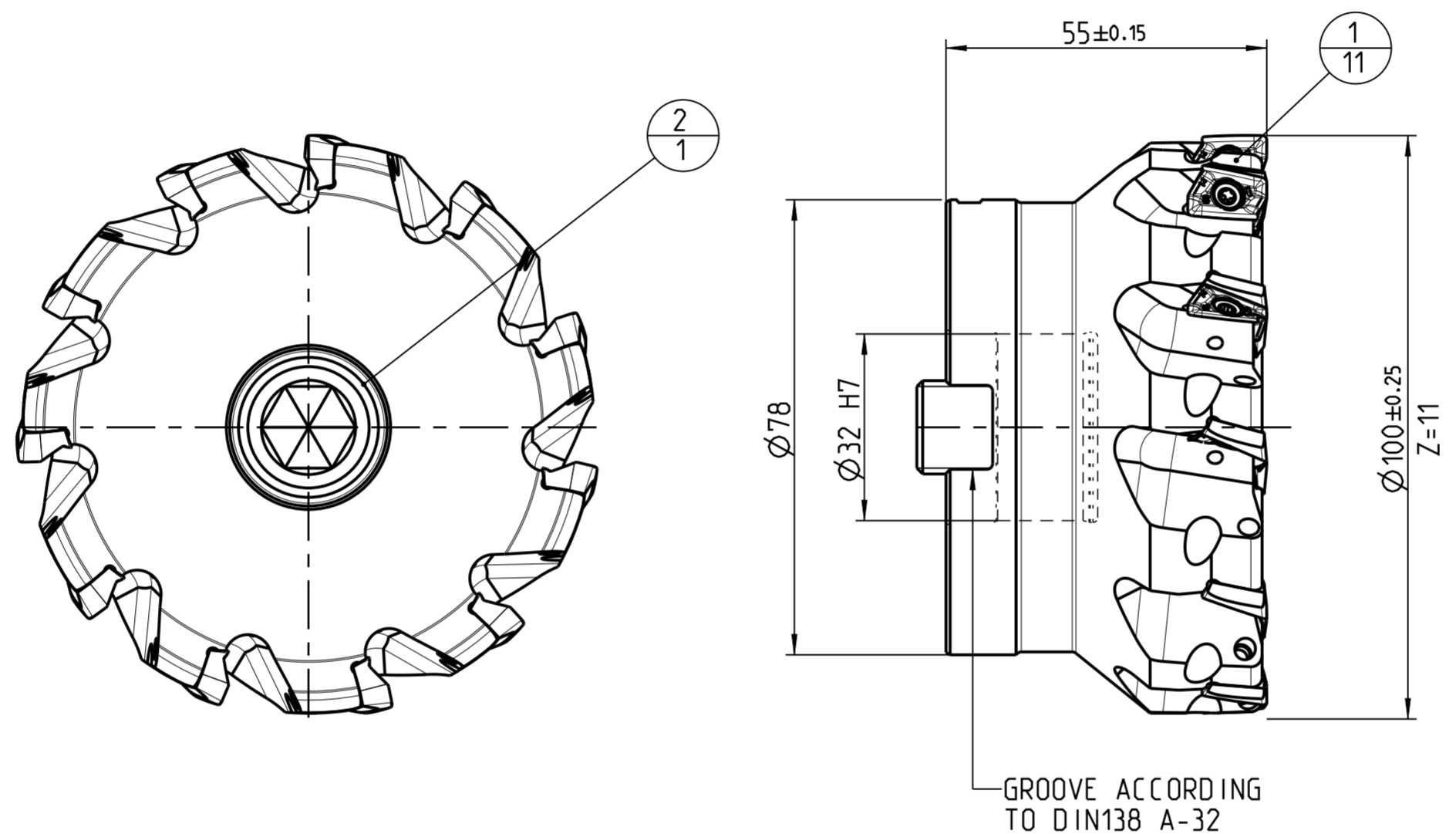

GROOVE ACCORDING TO DIN138 A-32

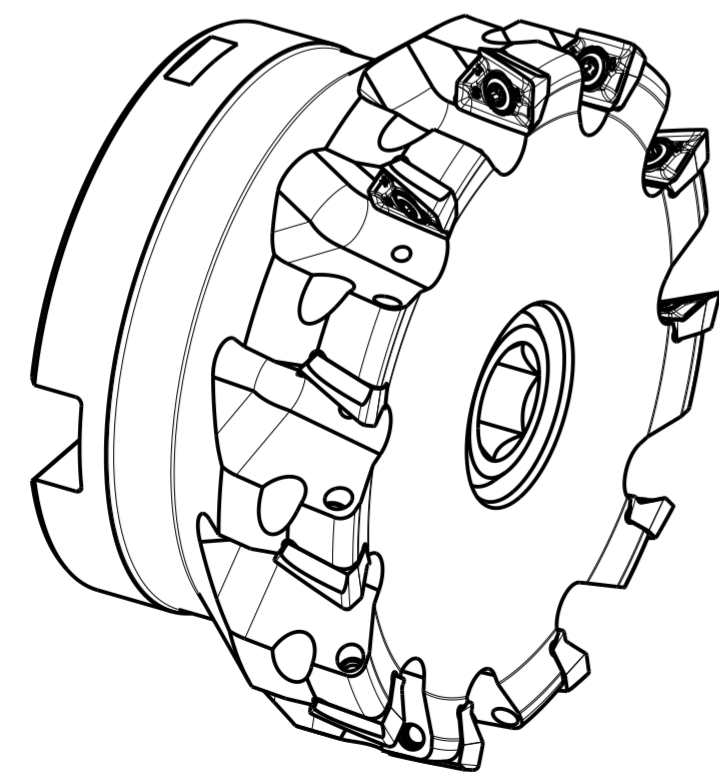

BALANCE GRADE PER DIN ISO 21940-11  
 G 6.3 / 3000 MIN<sup>-1</sup>  
 MASS APPROX. 2.1 kg

PART	TYP	QUAN.	UT	MATERIAL NUMBER	DESCRIPTION	TECHNICAL SPECIFICATION	CUSTOMER NUMBER
2	1			10003691	SOCKET HEAD SCREW	ISO 4762-M16x40-12.9	
1	11			30979520	TORX-SCREW	MN659 M3.5x8.1-TX10-1P	

SCOPE OF DELIVERY INFORMATION		TIGHTENING TORQUE FOR MAPAL CLAMPING SCREWS PER MN678BL1	
INSERTS NOT INCLUDED			
MAPAL © FABRIK FUER PRAEZISIONSWERKZEUGE DR. KRESS KG ALL RIGHTS FOR THE INVENTIONS, KNOW-HOW, TECHNICAL SOLUTIONS AND DESIGNS SHOWN ON THE DRAWING ARE ENTITLED TO MAPAL ONLY. AS FAR AS MAPAL DID NOT REGISTER PROPERTY RIGHTS HEREUPON YET, MAPAL FORMALY RESERVES THE RIGHT FOR THE REGISTRATION OF PROPERTY RIGHTS. THE DRAWING AS WELL AS THE MATTERS SHOWN ARE STRICTLY CONFIDENTIAL. REPRODUCTIONS MAY ONLY BE MADE FOR THE PURPOSE AGREED UPON. NEITHER THIS DRAWING NOR COPIES THEREOF MAY BE MADE ACCESSIBLE TO THIRD PARTIES. WITH THE DELIVERY OF THIS DRAWING NO RIGHT TO USE IT FOR ANY PURPOSE IS GRANTED. VIOLATIONS AGAINST THE OBLIGATIONS TO SECRECY AND USE RESTRICTIONS WILL BE PROSECUTED.		TITLE <b>90° FORM FACE CUTTER. INDEXABLE INSERTS</b> MAPAL Präzisionswerkzeuge Dr. Kress KG DATE OF ISSUE: 2021-09-22 CREATED: UNO DOCUMENT: 607614254-000-00-ED1 DATE APPROVED: MATERIAL NUMBER: 31281115	
GENERAL TOLERANCE ISO 2768-1H SIZE ISO 14405-1 ©		DIMENSIONS NOT SHOWN ARE MAPAL STANDARDS SCALE: 1:1 TECHNICAL SPECIFICATION: ICM901-100-CA32-Z11R-XP_T11	