

INDEX	CHANGES	DATE	NAME

NON TOLERANCED DIMENSIONS					
0.5	> 3	> 6	> 30	> 120	> 400
... 3	... 6	... 30	... 120	... 400	... 1000
± 0.1	± 0.1	± 0.2	± 0.3	± 0.5	± 0.8
RADII, CHAMFERS					
± 0.2	± 0.5	± 1	± 1	± 1	± 1
ANGLES, DIM. OF THE SHORTER SIDE					
bis 10	> 10	> 50	> 120	> 400	
... 50	... 120	... 400			
± 1°	± 30'	± 20'	± 10'	± 5'	

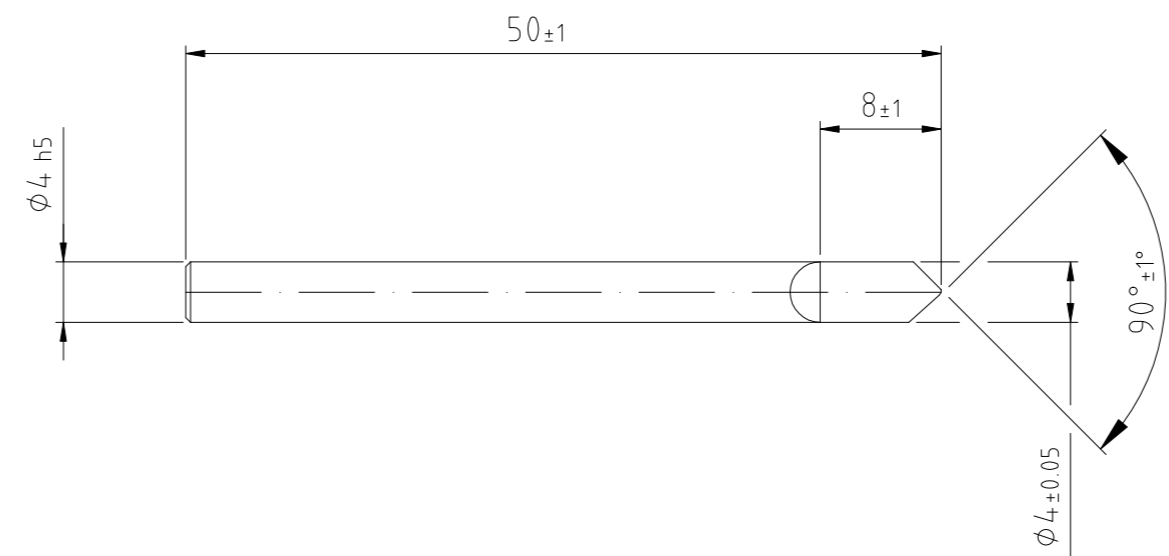
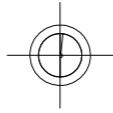

REGRINDING INFO	
TIP	<input type="radio"/>
OUTER DIAMETER	<input type="radio"/>
FLUTE	<input type="radio"/>
ADDING OF WORKING LENGTH	<input type="radio"/>
ADDING OF WORKING DIAMETER	<input type="radio"/>
DECOATING	<input type="radio"/>

● YES ○ OPTIONAL ○ NO

COMPONENT			MAPAL © FABRIK FUER PRAEZISIONSWERKZEUGE DR. KRESS KG			TITLE			OPTIMILL-GRAVER, SHANKFORM HA, SC, COATED			FORMAT	
PART FEATURE			ALL RIGHTS FOR THE INVENTIONS, KNOW-HOW, TECHNICAL SOLUTIONS AND DESIGNS SHOWN ON THE DRAWING ARE ENTITLED TO MAPAL ONLY. AS FAR AS MAPAL DID NOT REGISTER PROPERTY RIGHTS HEREUPON YET, MAPAL FORMALLY RESERVES THE RIGHT FOR THE REGISTRATION OF PROPERTY RIGHTS. THE DRAWING AS WELL AS THE MATTERS SHOWN ARE STRICTLY CONFIDENTIAL. REPRODUCTIONS MAY ONLY BE MADE FOR THE PURPOSE AGREED UPON. NEITHER THIS DRAWING NOR COPIES THEREOF MAY BE MADE ACCESSIBLE TO THIRD PARTIES. WITH THE DELIVERY OF THIS DRAWING NO RIGHT TO USE IT FOR ANY PURPOSE IS GRANTED. VIOLATIONS AGAINST THE OBLIGATIONS TO SECRECY AND USE RESTRICTIONS WILL BE PROSECUTED.			MAPAL		MAPAL Präzisionswerkzeuge Dr. Kress KG		DATE OF ISSUE	CREATED	DOCUMENT	INDEX
CUSTOMER COMPONENT REFERENCE						DATE	APPROVED	MATERIAL NUMBER	ORIGIN				
WORKPIECE MATERIAL	TOOL-NO.	OP-NO.	GENERAL TOLERANCE ISO 2768-mH		DIMENSIONS NOT SHOWN		SCALE	TECHNICAL SPECIFICATION	SHEET				
HARTBEARBEITUNG			SIZE ISO 14405-1		ARE MAPAL STANDARDS		2:1	SCM107-04.00Z01R-G0900HA-HP808	1/1				