

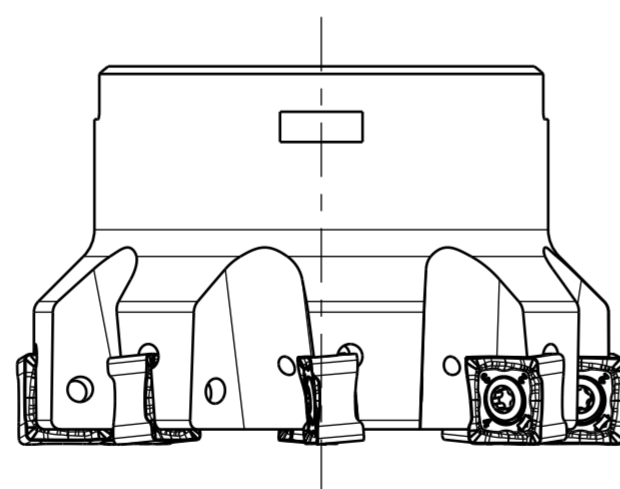

CLAMPING	SPARE PARTS	ALLOCATION OF PARTS	INDEX	CHANGES	DATE	NAME
		DIAMETER				
-	1	80				
-	-	-				
-	-	-				
-	-	-				
-	-	-				

UNEQUAL POSITIONING

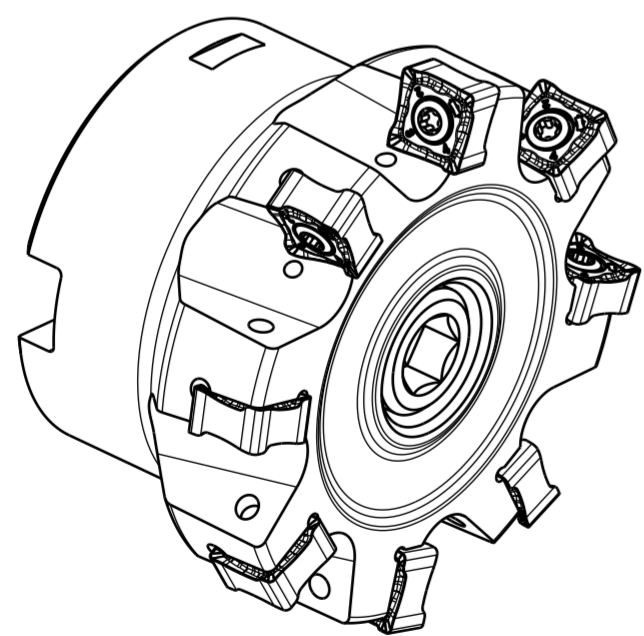
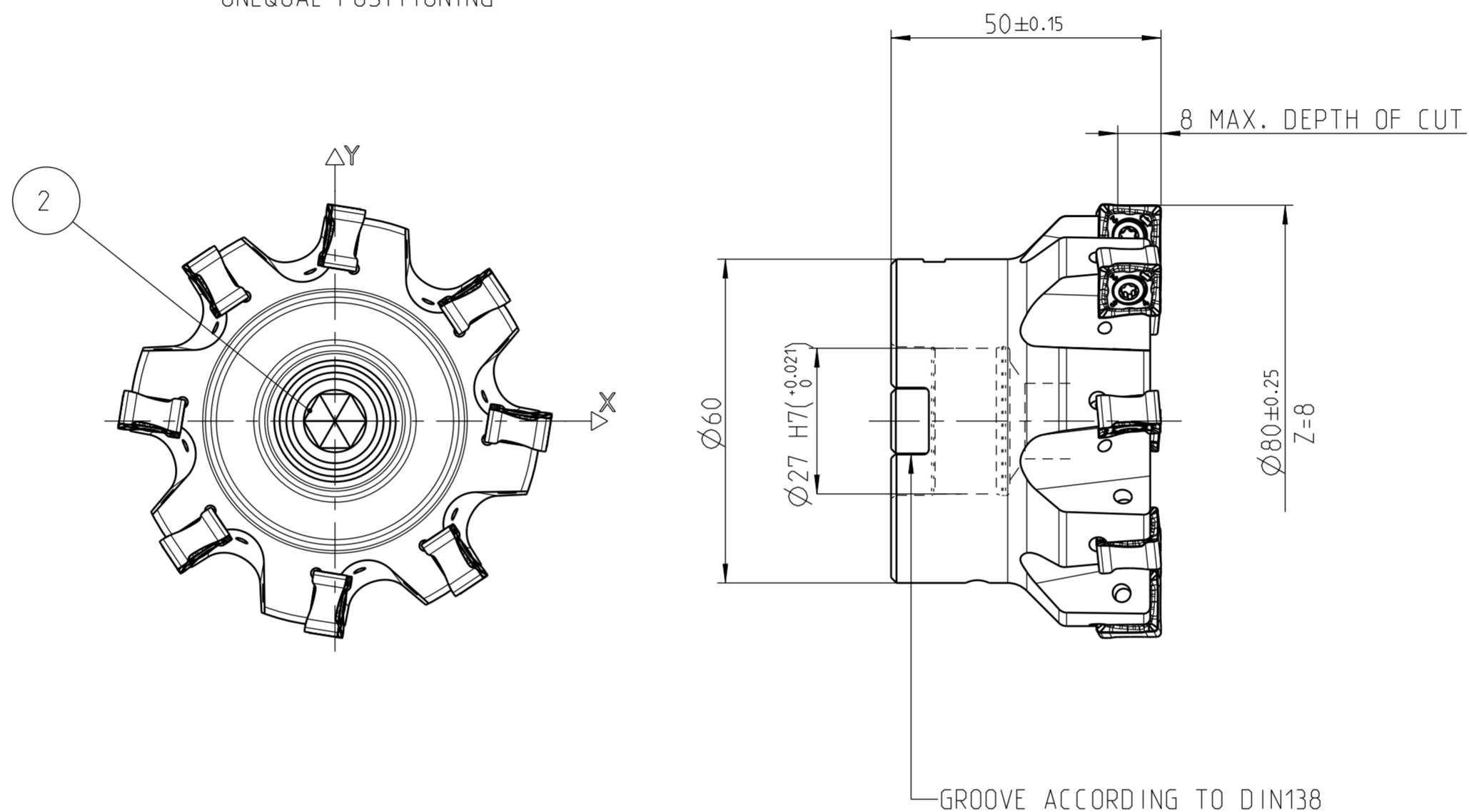

PART	TYP	QUAN.	UT	MATERIAL NUMBER	DESCRIPTION	TECHNICAL SPECIFICATION	CUSTOMER NUMBER
-	OPT	1		31008546	SOCKET HEAD SCREW	MN692BL4-M12X35-12.9-1K	
2		1		10003677	SOCKET HEAD SCREW	ISO 4762-M12X35-12.9	
1		8		10018468	TORX-SCREW	MN659 M4X11-TX15-IP	

SCOPE OF DELIVERY INFORMATION	BOM INFORMATION	TIGHTENING TORQUE FOR MAPAL CLAMPING SCREWS
INSERTS NOT INCLUDED	OPTIONAL PARTS (OPT) NOT INCLUDED SCOPE OF DELIVERY	PER MN678BL1

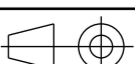
MAPAL © FABRIK FUER PRAEZISIONSWERKZEUGE DR. KRESS KG	TITLE RADIAL MILLING PROGRAMME. BODY	DATE OF ISSUE 2018-11-13	CREATED KLA	DOCUMENT 607041008-000-02-ED1	INDEX 00
ALL RIGHTS FOR THE INVENTIONS, KNOW-HOW, TECHNICAL SOLUTIONS AND DESIGNS SHOWN ON THE DRAWING ARE ENTITLED TO MAPAL ONLY. AS FAR AS MAPAL DID NOT REGISTER PROPERTY RIGHTS HEREUPON YET, MAPAL FORMALLY RESERVES THE RIGHT FOR THE REGISTRATION OF PROPERTY RIGHTS. THE DRAWING AS WELL AS THE MATTERS SHOWN ARE STRICTLY CONFIDENTIAL. REPRODUCTIONS MAY ONLY BE MADE FOR THE PURPOSE AGREED UPON. NEITHER THIS DRAWING NOR COPIES THEREOF MAY BE MADE ACCESSIBLE TO THIRD PARTIES. WITH THE DELIVERY OF THIS DRAWING NO RIGHT TO USE IT FOR ANY PURPOSE IS GRANTED. VIOLATIONS AGAINST THE OBLIGATIONS TO SECRECY AND USE RESTRICTIONS WILL BE PROSECUTED.	 MAPAL Präzisionswerkzeuge Dr. Kress KG	DATE	APPROVED	MATERIAL NUMBER 31002273	ORIGIN AAD
BALANCE GRADE PER DIN ISO 21940-11 G 6.3 / 3000 MIN ⁻¹ MASS APPROX. 1.1 kg	GENERAL TOLERANCE ISO 2768-1H SIZE ISO 14405-1Ⓢ	DIMENSIONS NOT SHOWN ARE MAPAL STANDARDS		SCALE 1:1	TECHNICAL SPECIFICATION ICM901-080-CA27-Z08R-SN_U12

BALANCE GRADE PER DIN ISO 21940-11
G 6.3 / 3000 MIN⁻¹
MASS
APPROX. 1.1 kg

FORMAT A2	INDEX 00	ORIGIN AAD	SHEET 1/1
--------------	-------------	---------------	--------------