



OPTIMILL-TRO-INOX

36.00° HELICAL FLUTET AT Ø4.00

CUT
MAT

HP826

MAT

11

REGRINDING INFO	
TIP	NO
OUTER DIAMETER [D1]	NO
FLUTE	NO
NECK LENGTH [L3]	NO
NECK DIAMETER [D3]	NO
DECOATING	NO

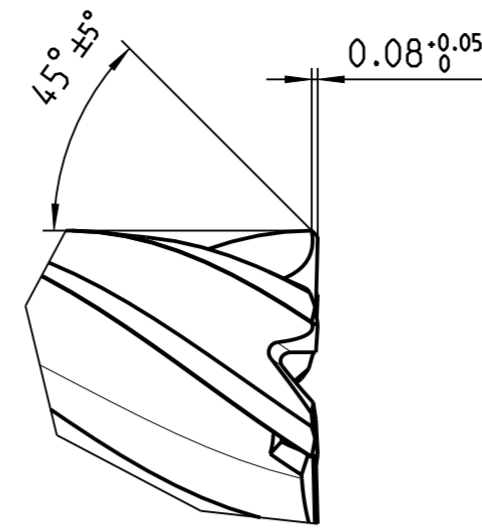

A
10:1

INDEX	CHANGES	DATE	NAME

NON TOLERANCED DIMENSIONS					
0.5	> 3	> 6	> 30	> 120	> 400
...3	...6	...30	...120	...400	...1000
± 0.1	± 0.1	± 0.2	± 0.3	± 0.5	± 0.8
RADII, CHAMFERS					
± 0.2	± 0.5	± 1	± 1	± 1	± 1
ANGLES, DIM. OF THE SHORTER SIDE					
bis 10	> 10	> 50	> 120	> 400	> 400
...50	...120	...400	...400	...400	...400
± 1°	± 30'	± 20'	± 10'	± 5'	± 5'

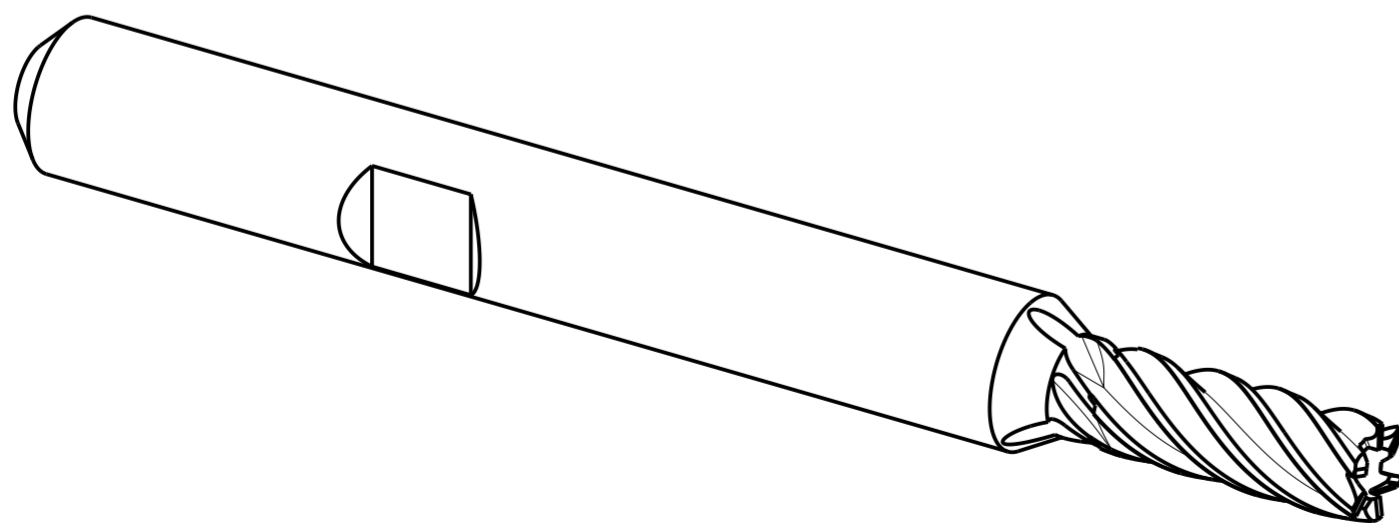
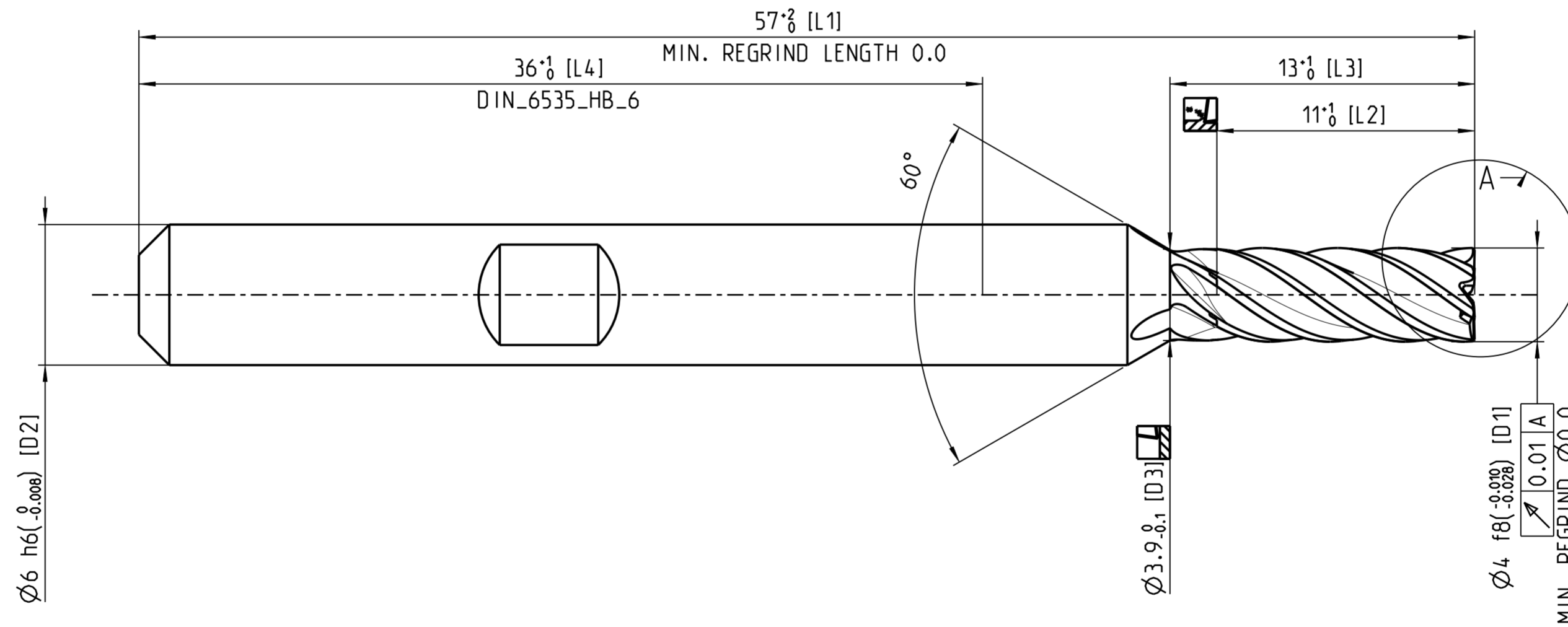
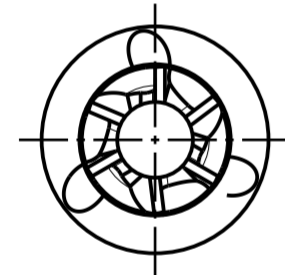

MASS
APPROX. 0.017 kg

MAPAL © FABRIK FUER PRAEZISIONSWERKZEUGE DR. KRESS KG <small>ALL RIGHTS FOR THE INVENTIONS, KNOW-HOW, TECHNICAL SOLUTIONS AND DESIGNS SHOWN ON THE DRAWING ARE ENTITLED TO MAPAL ONLY. AS FAR AS MAPAL DID NOT REGISTER PROPERTY RIGHTS HEREUPON YET, MAPAL FORMALLY RESERVES THE RIGHT FOR THE REGISTRATION OF PROPERTY RIGHTS. THE DRAWING AS WELL AS THE MATTERS SHOWN ARE STRICTLY CONFIDENTIAL. REPRODUCTIONS MAY ONLY BE MADE FOR THE PURPOSE AGREED UPON. NEITHER THIS DRAWING NOR COPIES THEREOF MAY BE MADE ACCESSIBLE TO THIRD PARTIES. WITH THE DELIVERY OF THIS DRAWING NO RIGHT TO USE IT FOR ANY PURPOSE IS GRANTED. VIOLATIONS AGAINST THE OBLIGATIONS TO SECRECY AND USE RESTRICTIONS WILL BE PROSECUTED.</small>		TITLE OPTIMILL-TRO-INOX, SHANKFORM HB, COATED			FORMAT A2
MAPAL Präzisionswerkzeuge Dr. Kress KG		DATE OF ISSUE 2024-11-29	CREATED DESIGN A.	DOCUMENT 607956987-000-00-ED1	INDEX 00
GENERAL TOLERANCE ISO 2768-mH SIZE ISO 14405-1 ©		DATE APPROVED	SCALE 5:1	MATERIAL NUMBER 31348624	ORIGIN ALD
DIMENSIONS NOT SHOWN ARE MAPAL STANDARDS				TECHNICAL SPECIFICATION SCM292-0400Z06R-F0008HB2-HP826	SHEET 1/1