

SPARE PARTS	ALLOCATION OF PARTS	INDEX NO.	CHANGES	DATE	NAME

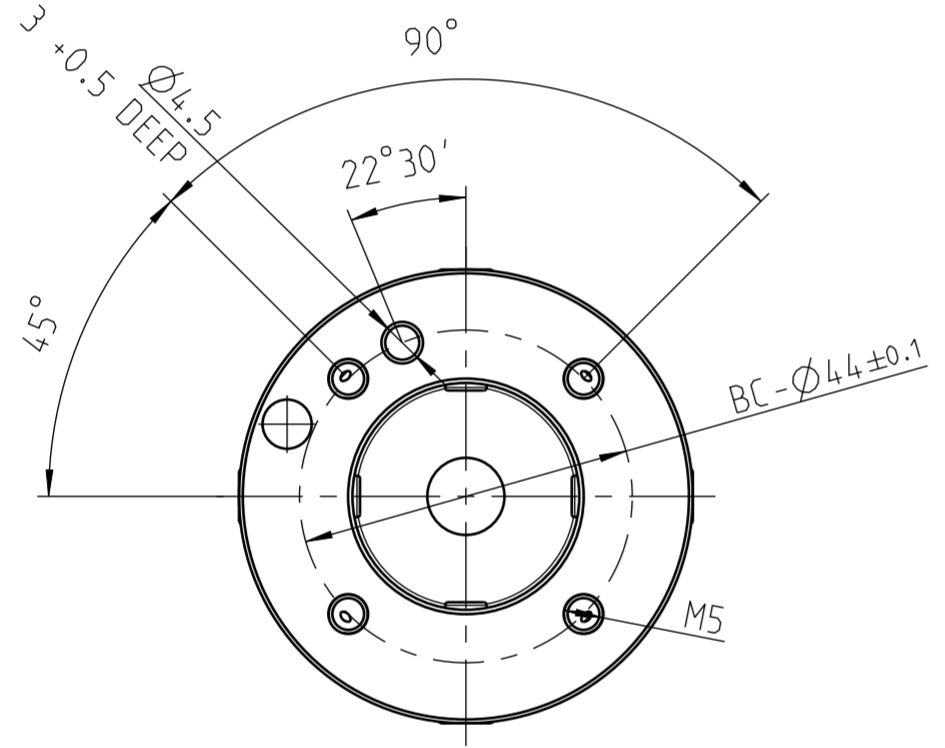

MN683-AD30-FC
PER MN683-BL2

MODULE 60
MN5000-14

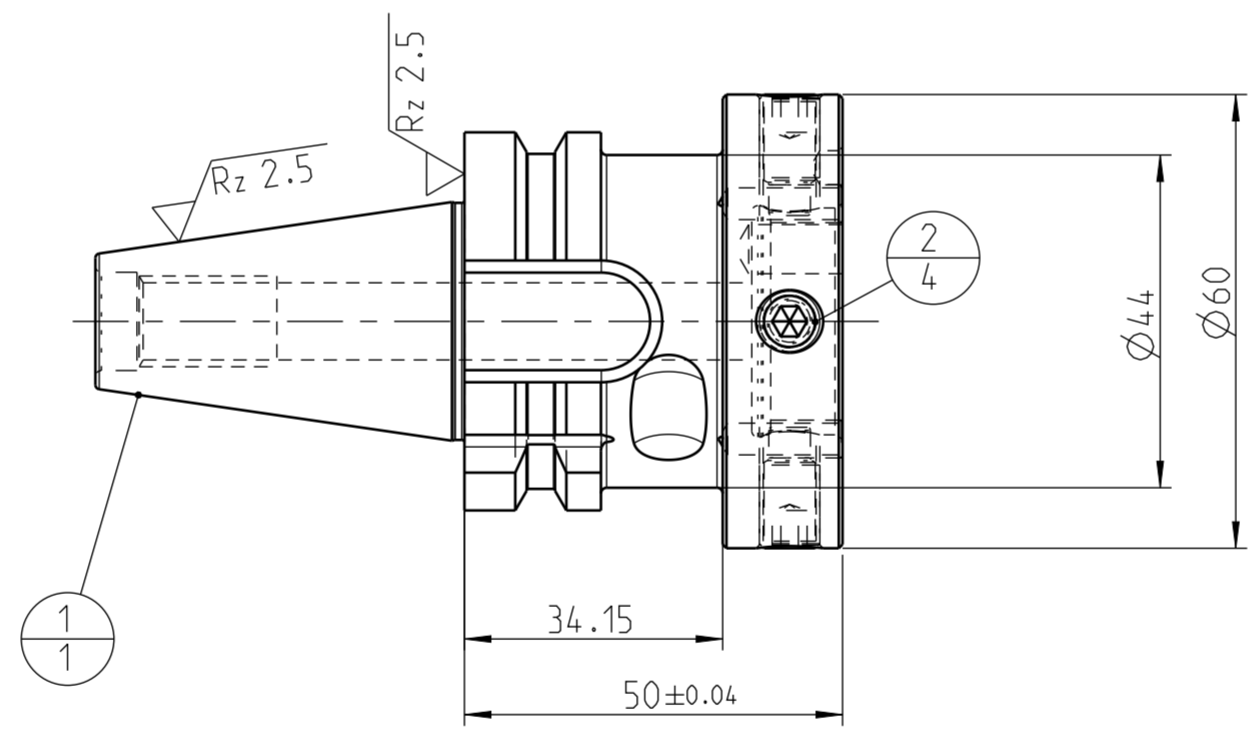

POSITION OF CUTTING EDGE
FOR TOOL WITH SINGLE CUTTING EDGE

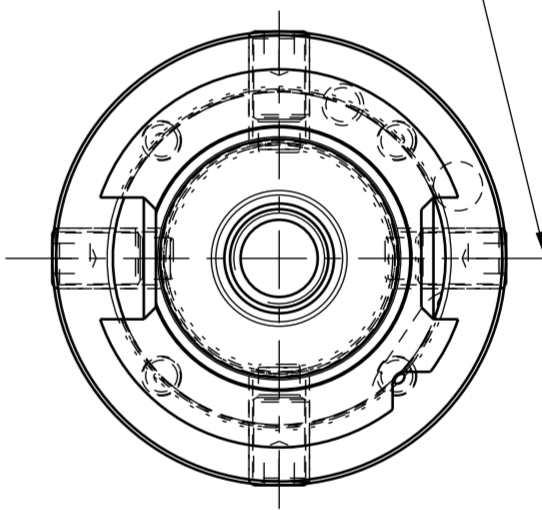

JOB-NO.:
PROJECT-NO.:
SKETCH:
CUSTOMER:
SIMILAR:
BARCODE-ZONE:

$\sqrt{Rz 2.5}$ ($\sqrt{Rz 6.3}$ $\sqrt{Rz 2.5}$)
CASE HARDENED HRC 60 ± 2
DEPTH OF CASEHARDENING 0.8
THREAD SOFT

MACH.-NO.:	STATION:	SPINDLE:
PART-NAME:		
PART-NO.:		
MATERIAL:		
TOOL-NO.:	OP-NO.:	HOLE-NO.:

PART	TYP	QUAN.	UT	MATERIAL NUMBER	DESCRIPTION	TECHNICAL SPECIFICATION	CUSTOMER NUMBER								
2		4		10075355	THREADED PIN	S.ISO 4028-M8X1X16-45H-KLF									
1		1			BODY										
BALANCE GRADE DIN ISO 1940-G 6.3 (COMPLETE ASSEMBLY) AT 3000 MIN ⁻¹					THIS DRAWING REMAINS OUR EXCLUSIVE PROPERTY. IT IS ENTRUSTED ONLY FOR THE PURPOSE AGREED UPON AND MAY NOT BE USED FOR ANY OTHER PURPOSE. COPIES OR OTHER REPRODUCTIONS MAY ONLY BE MADE FOR THE PURPOSE AGREED UPON. NEITHER ORIGINALS NOR REPRODUCTIONS MAY BE TRANSMITTED OR OTHERWISE MADE ACCESSIBLE TO A THIRD PARTY WITHOUT OUR WRITTEN CONSENT.	 MAPAL Präzisionswerkzeuge Dr. Kress KG	<table border="1"> <tr> <td>DATE</td> <td>NAME</td> </tr> <tr> <td>02.10.14</td> <td>BRT</td> </tr> <tr> <td>CHK.</td> <td></td> </tr> <tr> <td>APP.</td> <td></td> </tr> </table>	DATE	NAME	02.10.14	BRT	CHK.		APP.	
DATE	NAME														
02.10.14	BRT														
CHK.															
APP.															
ADDITIONALLY TO VA-NO. 07.05.01 MARK WITH:					DIMENSIONAL TOLERANCES PER ISO 2768-F UNLESS OTHERWISE SPECIFIED	DIMENSIONS NOT SHOWN ARE MAPAL STANDARDS	REGISTERED WITH GERMAN AND FOREIGN PATENT OFFICES								
TITLE:					STEEP TAPER ADAPTOR, FORM AD. WITH CONTACT FACE		ORIGIN AA1								
TECHNICAL SPECIFICATION:					MATERIAL NUMBER:	DRAWING NO.:	INDEX								
OS-AD-AD-FC030-MOD060-050-11					30630793	606355605-001-00-ED1	00								
REPLACES DWG. NO.:					REPLACED BY DWG. NO.:		SHEET 1 OF 1 SHEETS								