



OPTIMILL-UNI-HPC-PLUS

36° HELICAL FLUTET AT Ø20.00

CUT MAT

HP920

MAT

P/M/K

REGRINDING INFO	
TIP	YES
OUTER DIAMETER [D1]	YES
FLUTE	YES
NECK LENGTH [L3]	NO
NECK DIAMETER [D3]	YES
DECOATING	NO

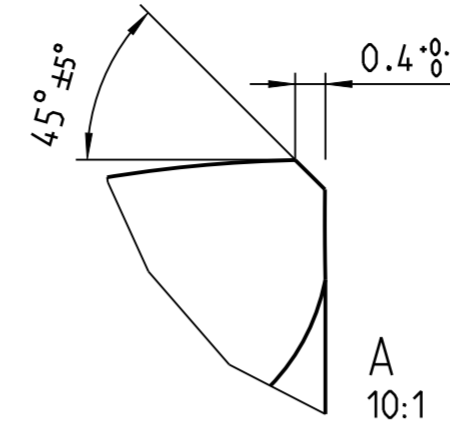

INDEX	CHANGES	DATE	NAME

NON TOLERANCED DIMENSIONS					
0.5	> 3	> 6	> 30	> 120	> 400
...3	...6	...30	...120	...400	...1000
± 0.1	± 0.1	± 0.2	± 0.3	± 0.5	± 0.8
RADII, CHAMFERS					
± 0.2	± 0.5	± 1	± 1	± 1	± 1
ANGLES, DIM. OF THE SHORTER SIDE					
bis 10	> 10	> 50	> 120	> 400	> 400
...10	...50	...120	...400	...400	...400
± 1°	± 30'	± 20'	± 10'	± 5'	± 5'

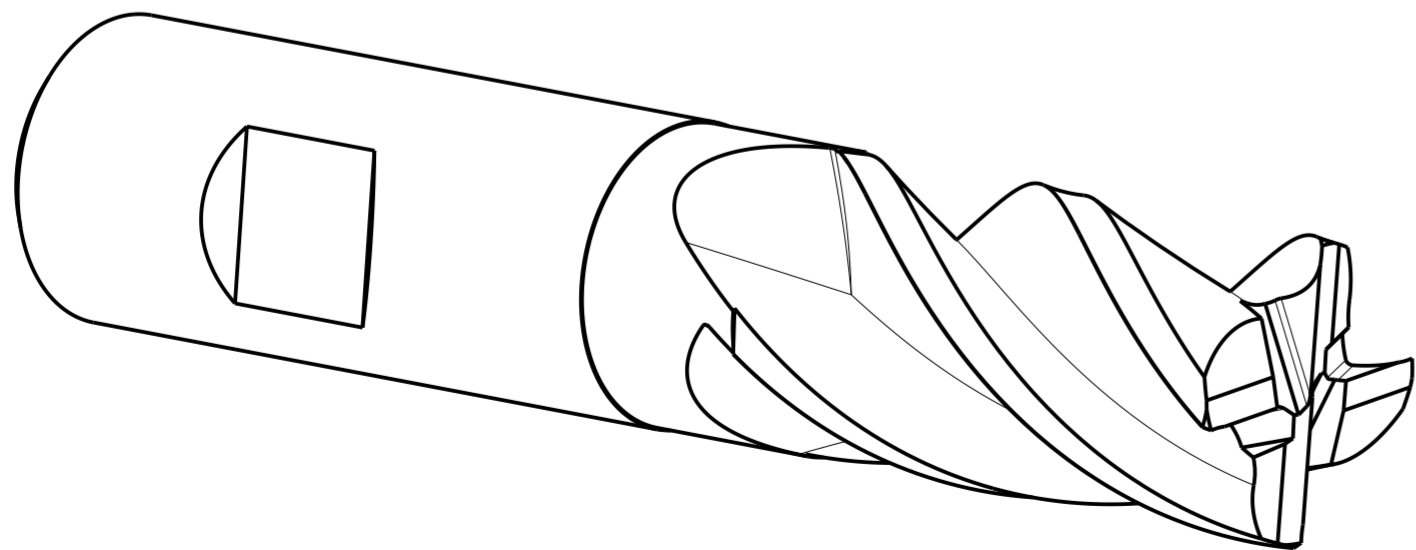
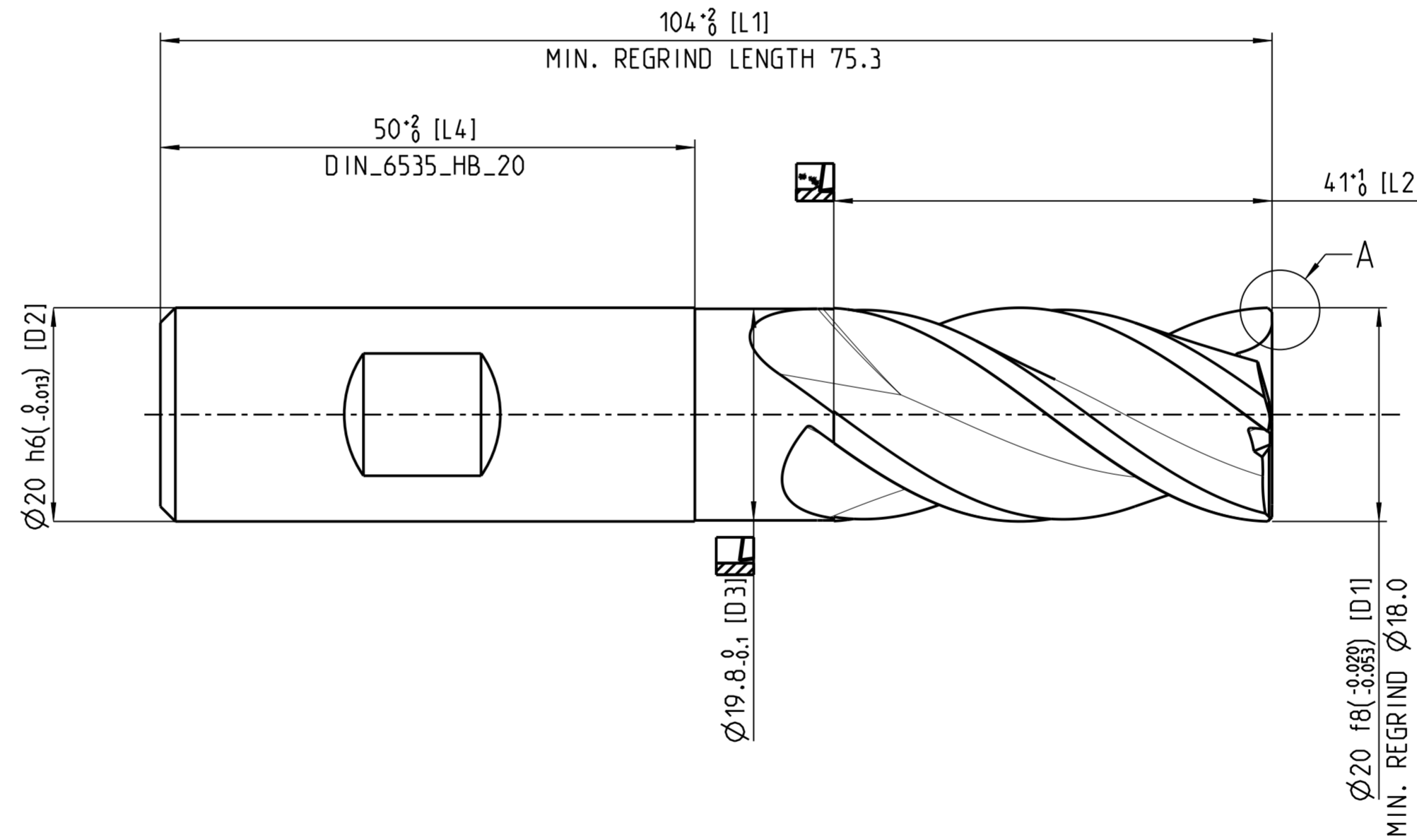
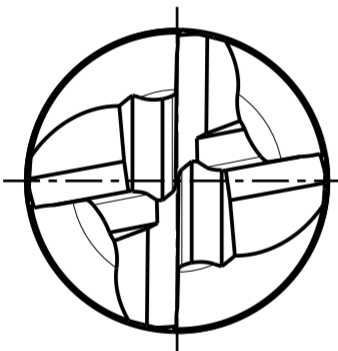

MASS  
APPROX. 0.391 kg

MAPAL © FABRIK FUER PRAEZISIONSWERKZEUGE DR. KRESS KG	TITLE OPTIMILL-UNI-HPC-PLUS. SHANKFORM HB. COATED	FORMAT A2
ALL RIGHTS FOR THE INVENTIONS, KNOW-HOW, TECHNICAL SOLUTIONS AND DESIGNS SHOWN ON THE DRAWING ARE ENTITLED TO MAPAL ONLY. AS FAR AS MAPAL DID NOT REGISTER PROPERTY RIGHTS HEREUPON YET, MAPAL FORMALLY RESERVES THE RIGHT FOR THE REGISTRATION OF PROPERTY RIGHTS. THE DRAWING AS WELL AS THE MATTERS SHOWN ARE STRICTLY CONFIDENTIAL. REPRODUCTIONS MAY ONLY BE MADE FOR THE PURPOSE AGREED UPON. NEITHER THIS DRAWING NOR COPIES THEREOF MAY BE MADE ACCESSIBLE TO THIRD PARTIES. WITH THE DELIVERY OF THIS DRAWING NO RIGHT TO USE IT FOR ANY PURPOSE IS GRANTED. VIOLATIONS AGAINST THE OBLIGATIONS TO SECRECY AND USE RESTRICTIONS WILL BE PROSECUTED.	<p>MAPAL Präzisionswerkzeuge Dr. Kress KG</p>	<p>DATE OF ISSUE 2025-02-25</p> <p>CREATED DESIGN A.</p> <p>DOCUMENT 607051823-000-00-ED1</p> <p>MATERIAL NUMBER <b>30787393</b></p> <p>TECHNICAL SPECIFICATION SCM770-2000Z04R-F0040HB-HP920</p>
GENERAL TOLERANCE ISO 2768-mH SIZE ISO 14405-1 Ⓢ	DIMENSIONS NOT SHOWN ARE MAPAL STANDARDS	<p>INDEX 00</p> <p>ORIGIN ALD</p> <p>SHEET 1/1</p>