



OPTIMILL-HARDENED-FINISH

55.00° HELICAL FLUTET AT Ø5.00

HP808

REGRINDING INFO	
TIP	YES
OUTER DIAMETER	OPT
FLUTE	OPT
ADDING OF WORKING LENGTH	NO
ADDING OF WORKING DIAMETER	NO
DECOATING	NO

INDEX	CHANGES	DATE	NAME

NON TOLERANCED DIMENSIONS					
0.5	> 3	> 6	> 30	> 120	> 400
...3	...6	...30	...120	...400	1000
±0.1	±0.1	±0.2	±0.3	±0.5	±0.8

RADII, CHAMFERS					
±0.2	±0.5	±1	±1	±1	±1

ANGLES, DIM. OF THE SHORTER SIDE				
bis 10	> 10	> 50	> 120	> 400
...50	...120	...400		
±1°	±30'	±20'	±10'	±5'

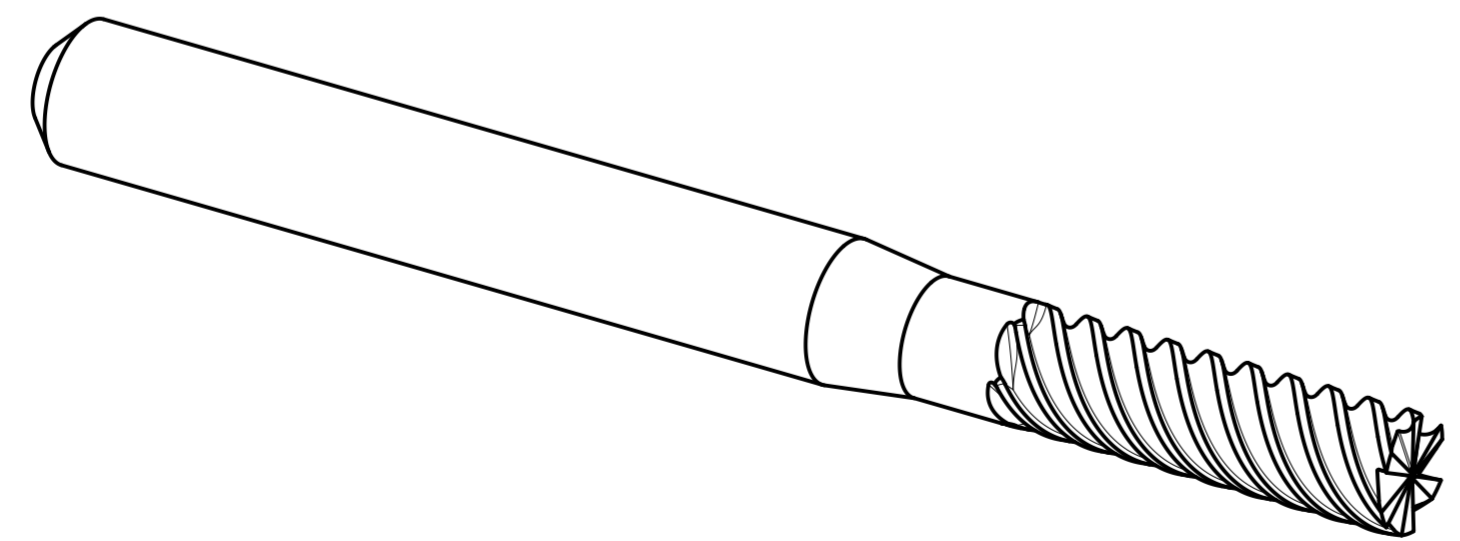
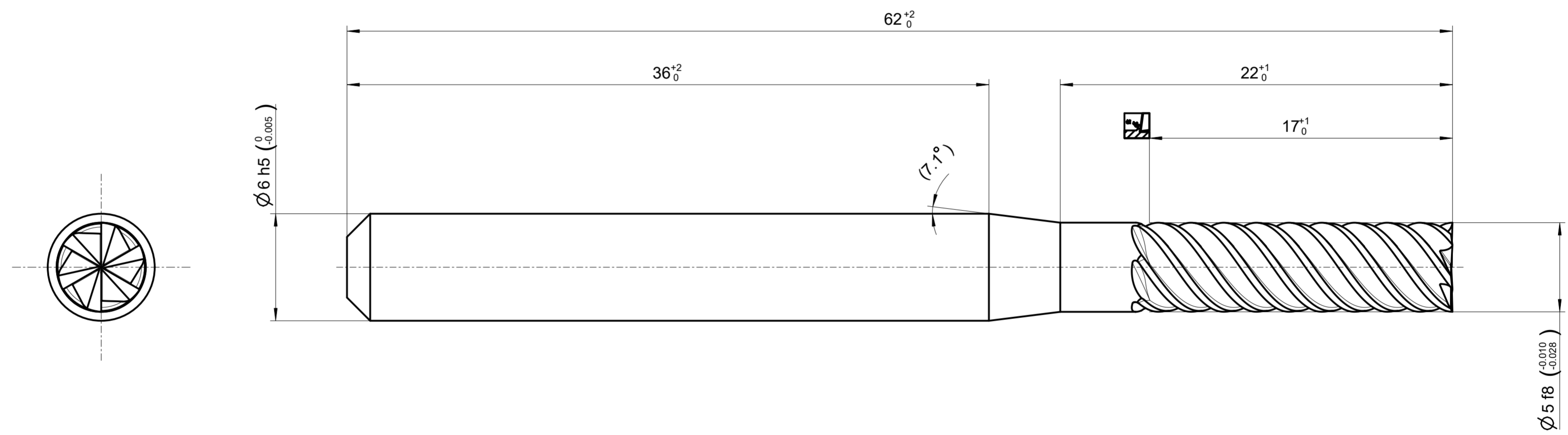

MASSE
CA. 0.021 kg

MAPAL © FABRIK FUER PRAEZISIONSWERKZEUGE DR. KRESS KG <small>ALL RIGHTS FOR THE INVENTIONS, KNOW-HOW, TECHNICAL SOLUTIONS AND DESIGNS SHOWN ON THE DRAWING ARE ENTITLED TO MAPAL ONLY. AS FAR AS MAPAL DID NOT REGISTER PROPERTY RIGHTS HEREUPON YET, MAPAL FORMALLY RESERVES THE RIGHT FOR THE REGISTRATION OF PROPERTY RIGHTS. THE DRAWING AS WELL AS THE MATTERS SHOWN ARE STRICTLY CONFIDENTIAL. REPRODUCTIONS MAY ONLY BE MADE FOR THE PURPOSE AGREED UPON. NEITHER THIS DRAWING NOR COPIES THEREOF MAY BE MADE ACCESSIBLE TO THIRD PARTIES. WITH THE DELIVERY OF THIS DRAWING NO RIGHT TO USE IT FOR ANY PURPOSE IS GRANTED. VIOLATIONS AGAINST THE OBLIGATIONS TO SECRECY AND USE RESTRICTIONS WILL BE PROSECUTED.</small>	TITLE OPTIMILL-HARDENED-FINISH, SHANKFORM HA, COATED			FORMAT A2
	MAPAL Präzisionswerkzeuge Dr. Kress KG	DATE OF ISSUE 2024-02-16	CREATED VENU	DOCUMENT 608035322-000-00-ED1
GENERAL TOLERANCE ISO 2768-FH SIZE ISO 14405-1	DIMENSIONS NOT SHOWN ARE MAPAL STANDARDS	SCALE 5:1	MATERIAL NUMBER 31152776	ORIGIN COD
TECHNICAL SPECIFICATION SCM104-0500Z06R-S-HA3-HP808	SHEET 1/1			