

CLAMPING	SPARE PARTS	ALLOCATION OF PARTS	INDEX	CHANGES	DATE	NAME
		DIAMETER				
-	1	125				
-	-	-				
-	-	-				
-	-	-				

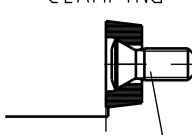
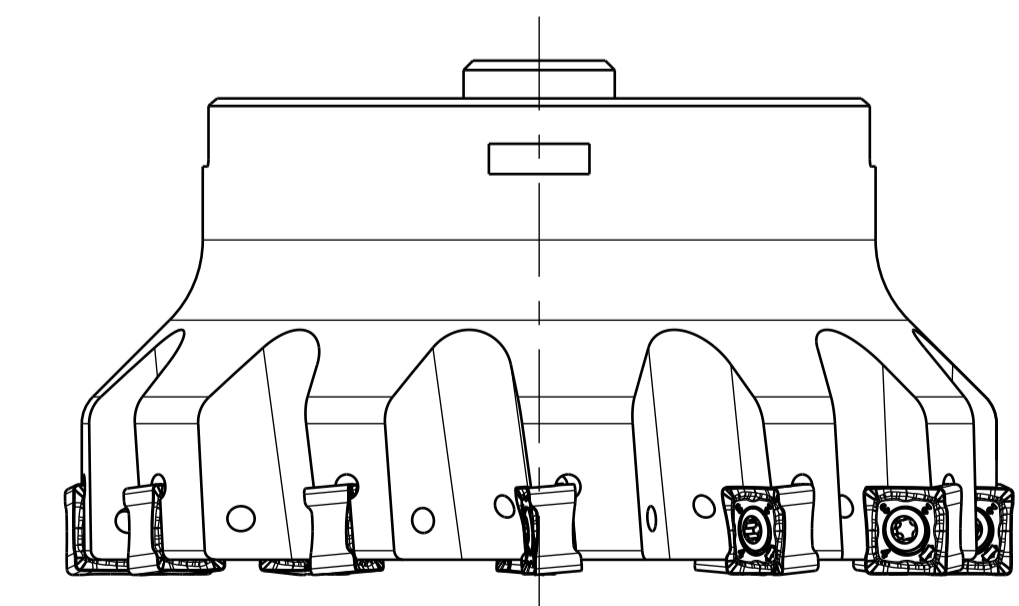
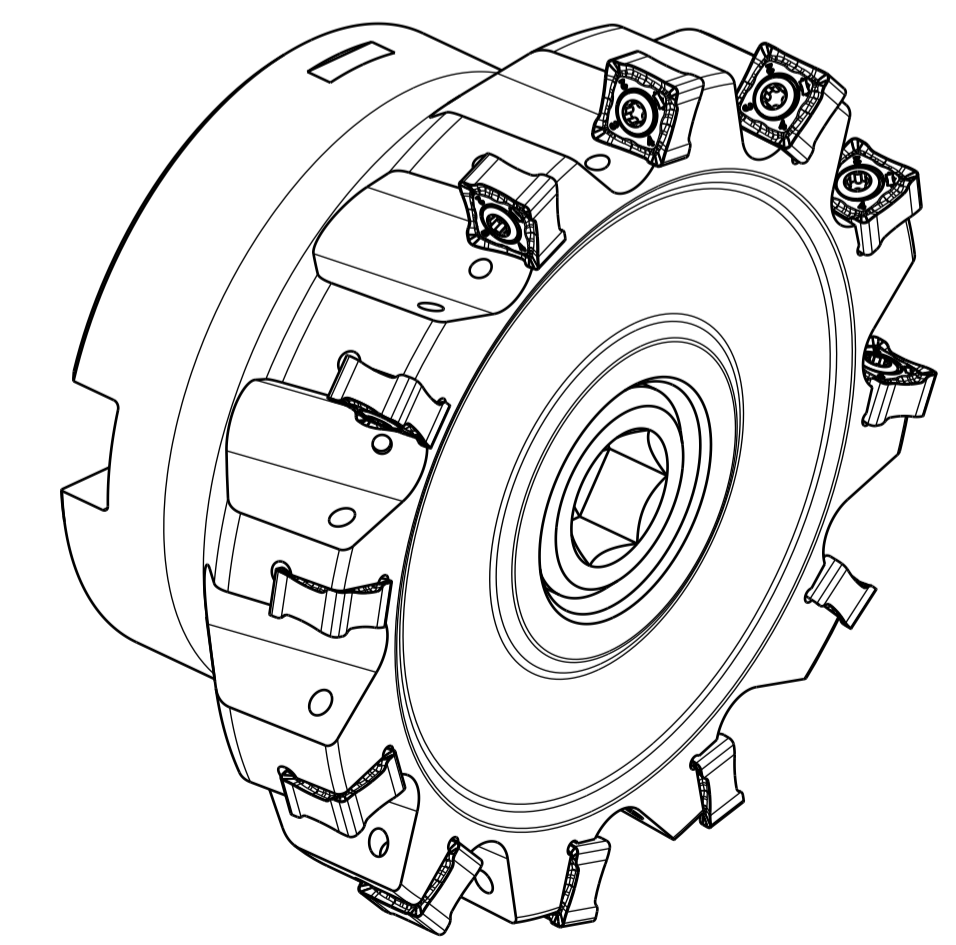
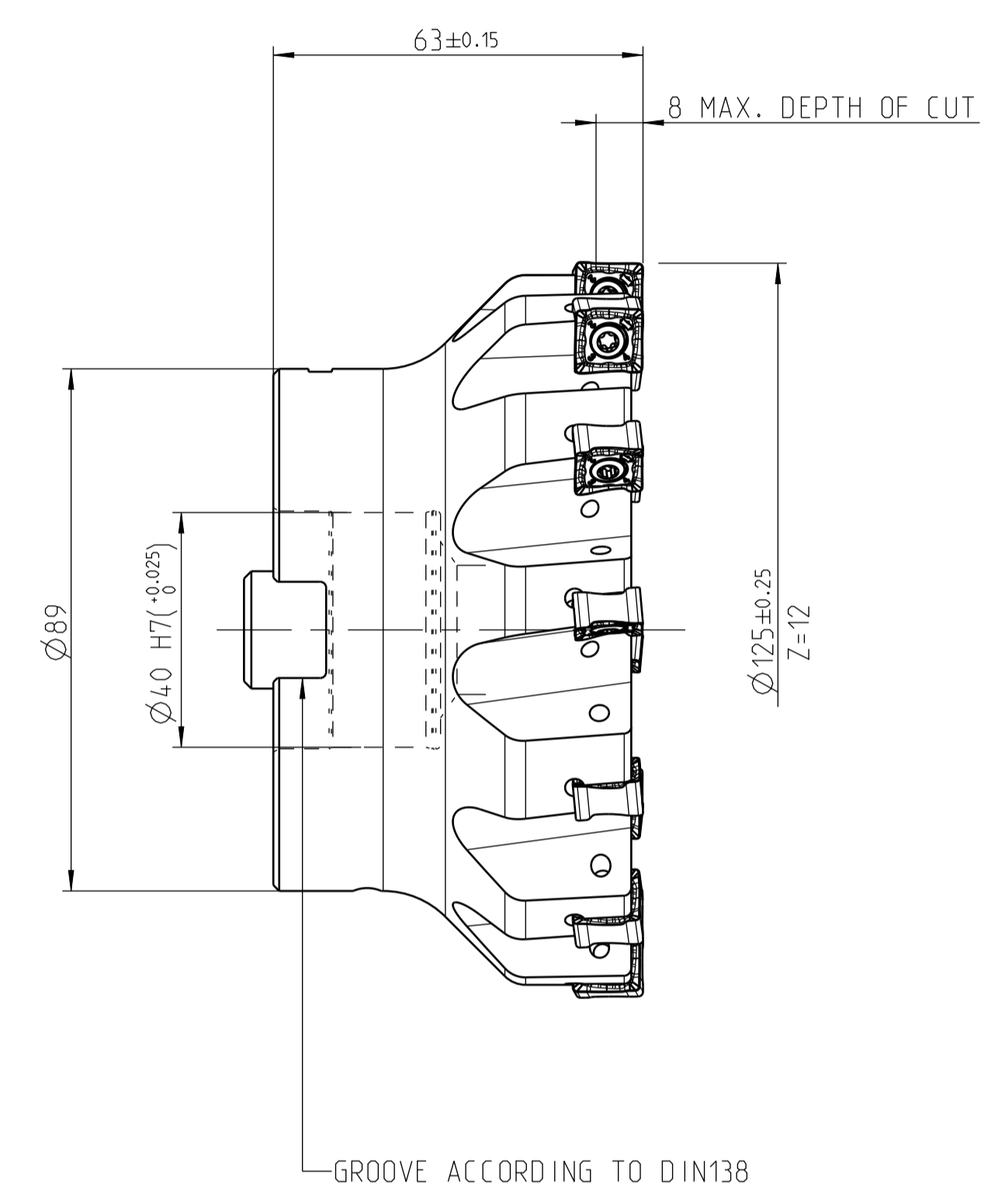
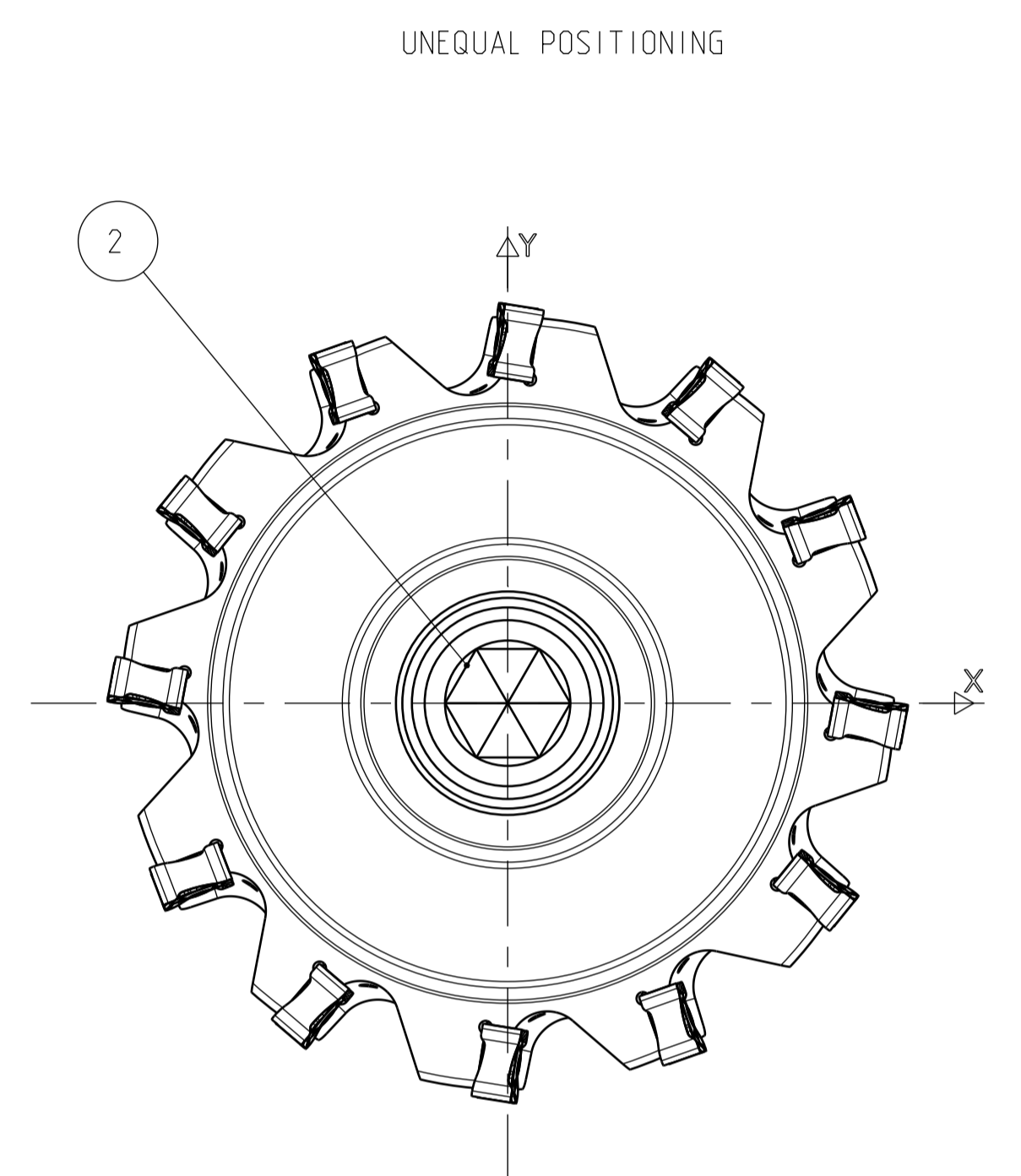

PART	TYP	QUAN.	UT	MATERIAL NUMBER	DESCRIPTION	TECHNICAL SPECIFICATION	CUSTOMER NUMBER
-	OPT	1		31009716	SOCKET HEAD SCREW	MN692BL4-M20X45-12.9-1K	-
2		1		10015924	SOCKET HEAD SCREW	ISO 4762-M20X45-10.9	-
1		12		10018468	TORX-SCREW	MN659 M4X11-TX15-1P	-

SCOPE OF DELIVERY INFORMATION		BOM INFORMATION		TIGHTENING TORQUE FOR MAPAL CLAMPING SCREWS PER MN678BL1	
INSERTS NOT INCLUDED		OPTIONAL PARTS (OPT) NOT INCLUDED SCOPE OF DELIVERY			
MAPAL © FABRIK FUER PRÄZISIONSWERKZEUGE DR. KRESS KG		TITLE RADIAL MILLING PROGRAMME, BODY		DATE OF ISSUE 2018-11-13	CREATED KLA
ALL RIGHTS FOR THE INVENTIONS, KNOW-HOW, TECHNICAL SOLUTIONS AND DESIGN SHOWN ON THE DRAWING ARE ENTITLED TO MAPAL ONLY. AS FAR AS MAPAL DID NOT REGISTER PROPERLY RIGHTS HEREON YET, MAPAL FORMALY RESERVES THE RIGHT FOR THE REGISTRATION OF PROPERLY RIGHTS. THE DRAWING AS WELL AS THE MATTERS SHOWN ARE STRICTLY CONFIDENTIAL. REPRODUCTIONS MAY ONLY BE MADE FOR THE PURPOSE AGREED UPON. NEITHER THIS DRAWING NOR COPIES THEREOF MAY BE MADE ACCESSIBLE TO THIRD PARTIES. WITH THE DELIVERY OF THIS DRAWING NO RIGHT TO USE IT FOR ANY PURPOSE IS GRANTED. VIOLATIONS AGAINST THE OBLIGATIONS TO SECRECY AND USE RESTRICTIONS WILL BE PROSECUTED.		MAPAL Präzisionswerkzeuge Dr. Kress KG		DATE APPROVED	DOCUMENT 607041010-000-02-ED1 MATERIAL NUMBER 31002275
BALANCE GRADE PER DIN ISO 21940-11 G 6.3 / 3000 MIN <sup>-1</sup> MASS APPROX. 3.5 kg		GENERAL TOLERANCE ISO 2768-H SIZE ISO 14405-1(Ⓢ)		DIMENSIONS NOT SHOWN ARE MAPAL STANDARDS	SCALE 1:1
				TECHNICAL SPECIFICATION 1CM901-125-C A40-Z12R-SN_L12	ORIGIN A.A.D SHEET 1/1