

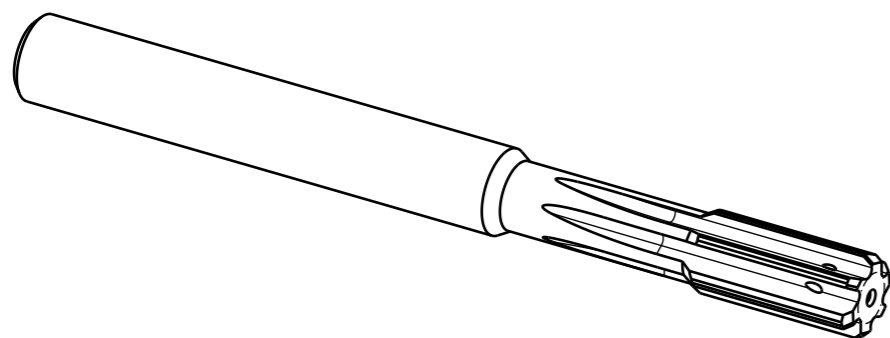
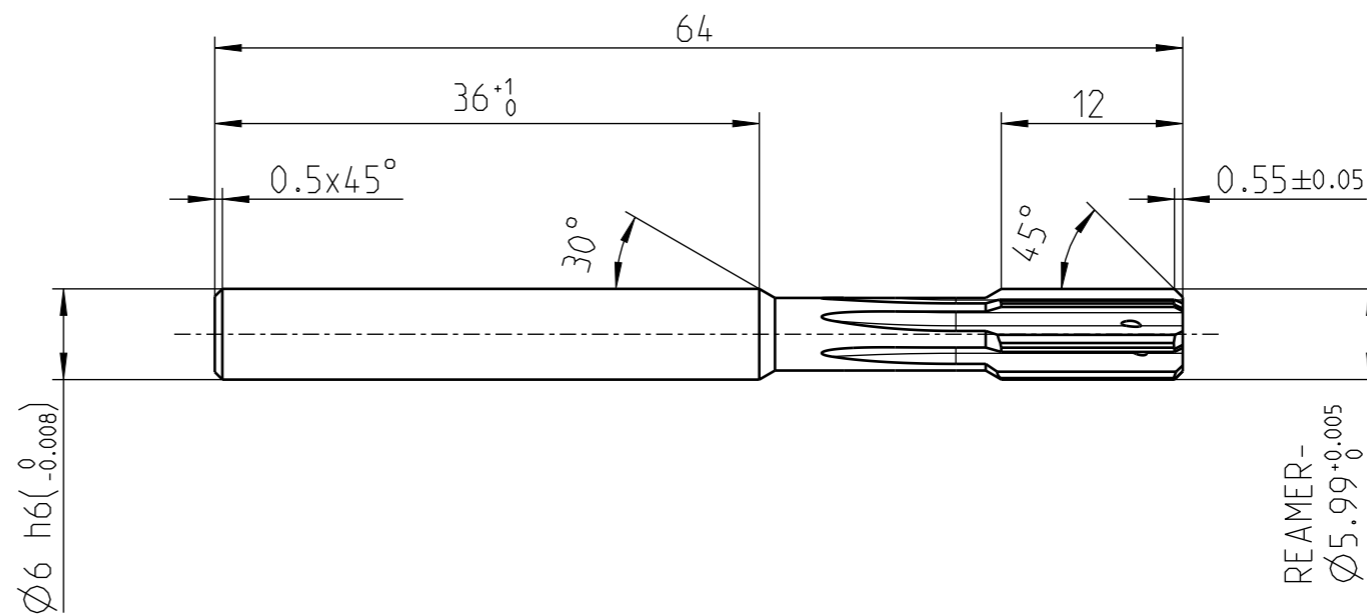
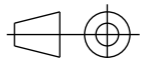

6 CUTTING EDGE, STRAIGHT FLUTED, RIGHT HAND CUTTING

INDEX	CHANGES	DATE	NAME

IC FOR
 THROUGH HOLE +
 BLIND HOLE

POS	TYP	MENGE	ME	MATERIALNUMMER	BENENNUNG	TECHNISCHE SPEZIFIKATION	KUNDENUMMER		
MAPAL © FABRIK FUER PRAEZISIONSWERKZEUGE DR. KRESS KG					TITLE FIXREAM PLUS. SOLID CARBIDE. COATED		FORMAT A3		
<small>ALL RIGHTS FOR THE INVENTIONS, KNOW-HOW, TECHNICAL SOLUTIONS AND DESIGNS SHOWN ON THE DRAWING ARE ENTITLED TO MAPAL ONLY. AS FAR AS MAPAL DID NOT REGISTER PROPERTY RIGHTS HEREUPON YET, MAPAL FORMALLY RESERVES THE RIGHT FOR THE REGISTRATION OF PROPERTY RIGHTS. THE DRAWING AS WELL AS THE MATTERS SHOWN ARE STRICTLY CONFIDENTIAL. REPRODUCTIONS MAY ONLY BE MADE FOR THE PURPOSE AGREED UPON. NEITHER THIS DRAWING NOR COPIES THEREOF MAY BE MADE ACCESSIBLE TO THIRD PARTIES. WITH THE DELIVERY OF THIS DRAWING NO RIGHT TO USE IT FOR ANY PURPOSE IS GRANTED. VIOLATIONS AGAINST THE OBLIGATIONS TO SECRECY AND USE RESTRICTIONS WILL BE PROSECUTED.</small>					 MAPAL Präzisionswerkzeuge Dr. Kress KG	DATE OF ISSUE 2023-11-14	CREATED GAT	DOCUMENT 607846116-000-00-ED1	INDEX 00
						DATE	APPROVED	MATERIAL NUMBER 31375277	ORIGIN W ID
GENERAL TOLERANCE ISO 2768-fH SIZE ISO 14405-1 Ⓢ					DIMENSIONS NOT SHOWN ARE MAPAL STANDARDS	 SCALE 2:1	TECHNICAL SPECIFICATION FXR507G05.990+5MJ1G-HP900	SHEET 1/1	