

CLAMPING	SAME PARTS	ALLOCATION OF PARTS	INDEX	CHANGES	DATE	NAME
	1	160				

UNEQUAL POSITIONING

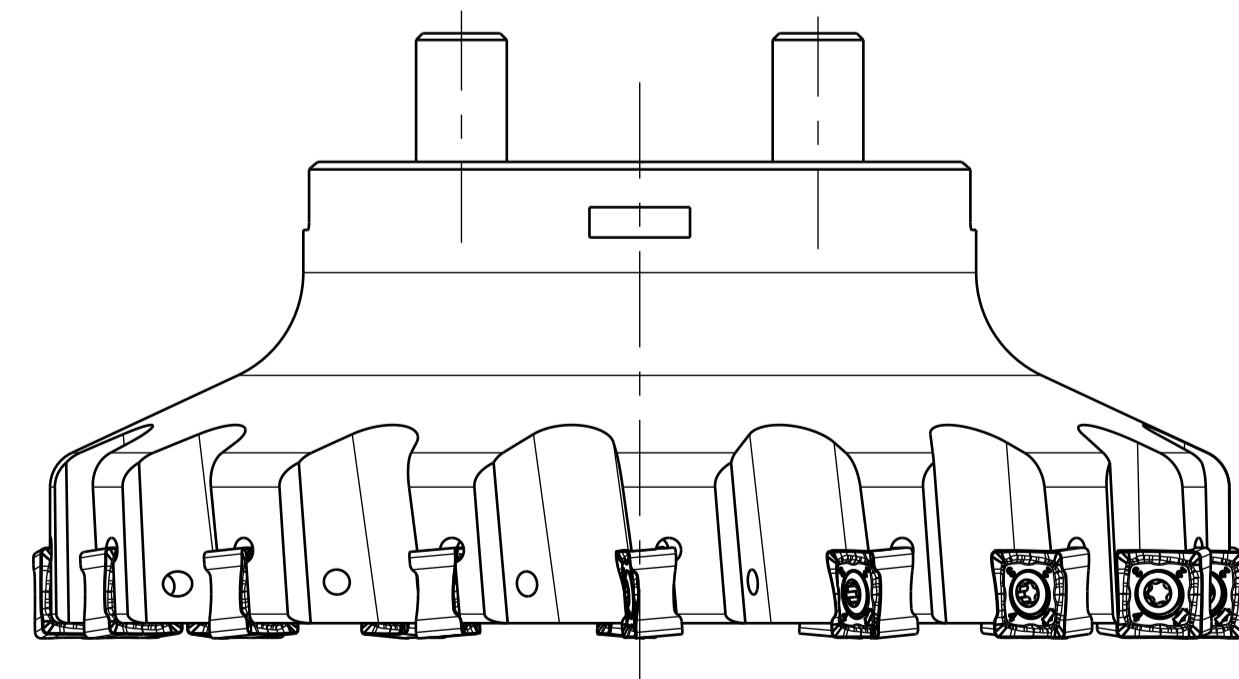
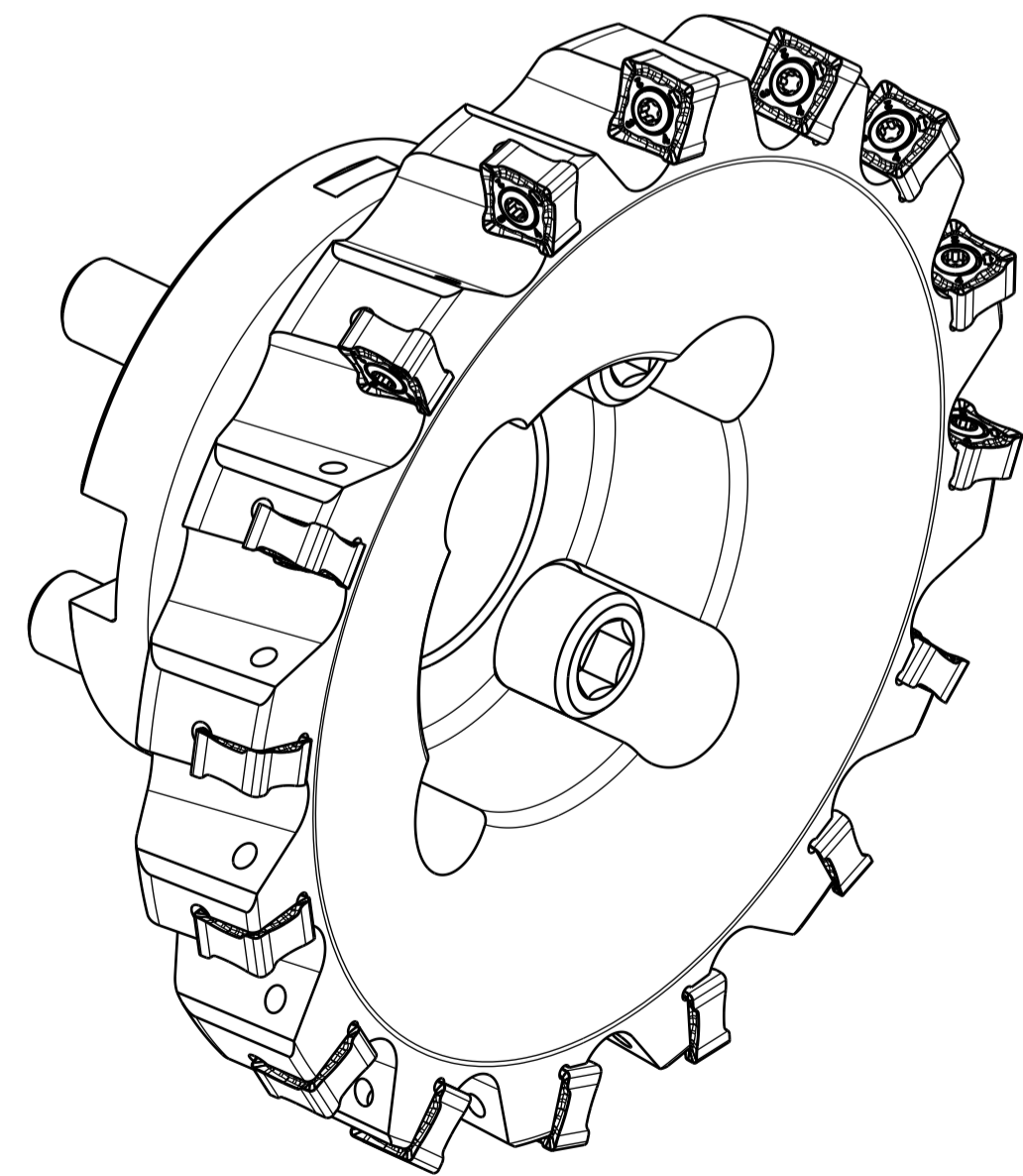
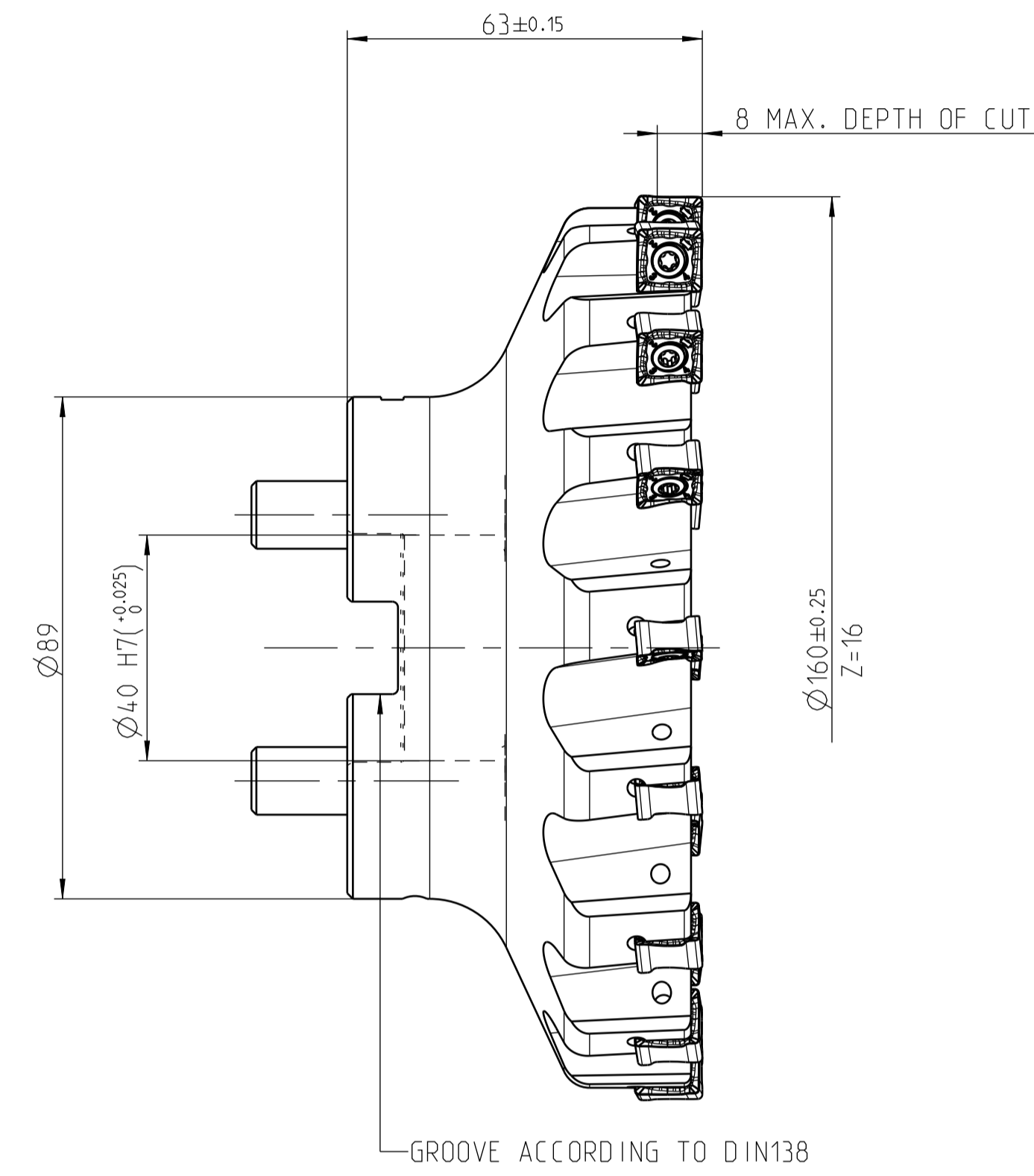
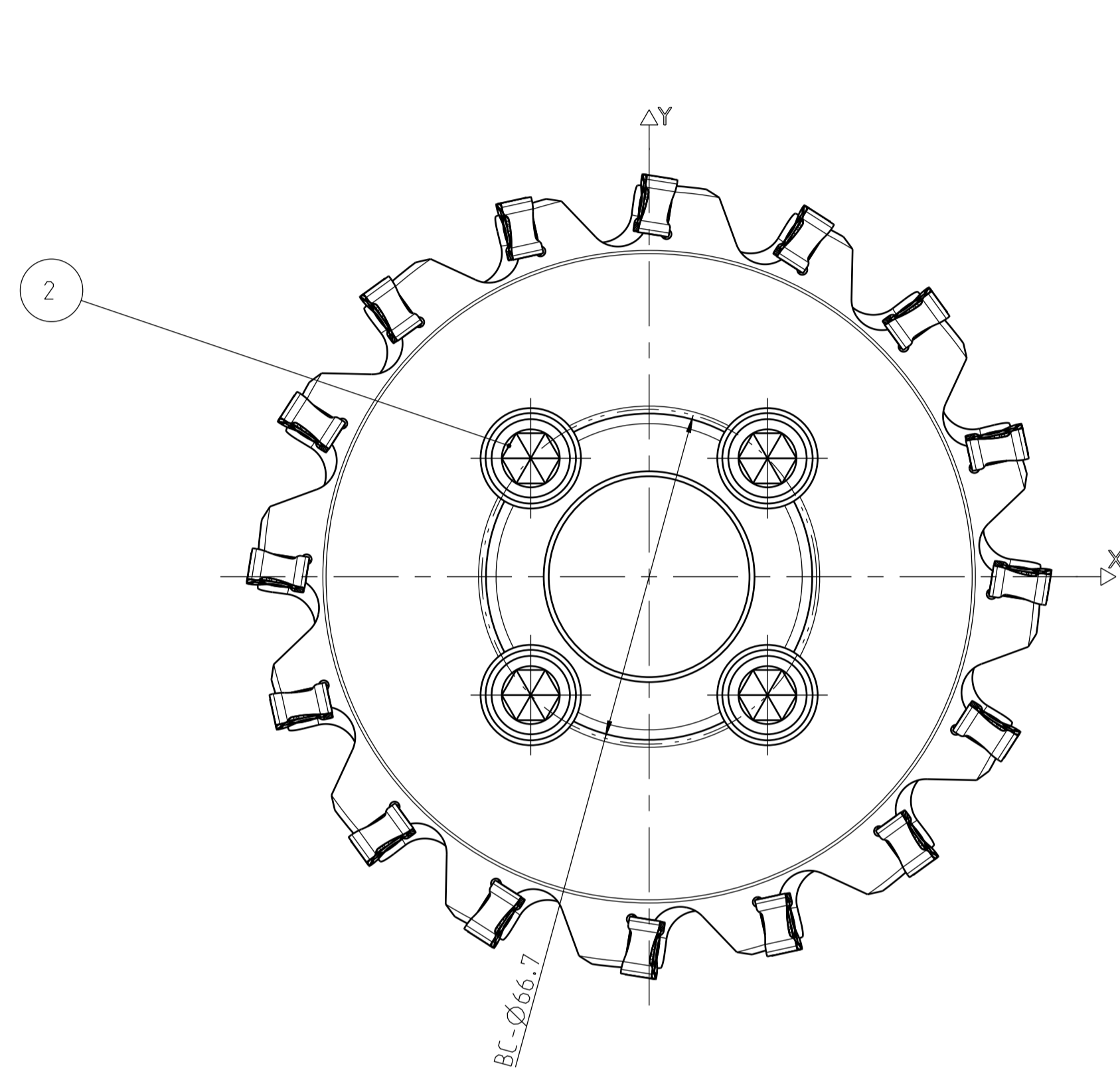

PART	TYP	QUAN.	UT	MATERIAL NUMBER	DESCRIPTION	TECHNICAL SPECIFICATION	CUSTOMER NUMBER
2		4		10006594	SOCKET HEAD SCREW	ISO 4762-M12x4.5-12.9	
-	OPT	1		10004066	CUTTER CLAMPING SCREW	DIN 6367-M20	
1		16		10018468	TORX-SCREW	MN659 M4x11-TX15-1P	

SCOPE OF DELIVERY INFORMATION		BOM INFORMATION		TIGHTENING TORQUE FOR MAPAL CLAMPING SCREWS PER MN678BL1	
INSERTS NOT INCLUDED		OPTIONAL PARTS (OPT) NOT INCLUDED SCOPE OF DELIVERY			
MAPAL © FABRIK FUER PRÄZISIONSWERKZEUGE DR. KRESS KG		TITLE RADIAL MILLING PROGRAMME, BODY		FORMAT A1	
ALL RIGHTS FOR THE INVENTIONS, KNOW-HOW, TECHNICAL SOLUTIONS AND DECISIONS SHOWN ON THE DRAWING ARE ENTITLED TO MAPAL ONLY. AS FAR AS MAPAL DID NOT REGISTER PROPERTY RIGHTS HEREON YET, MAPAL FORMALLY RESERVES THE RIGHT FOR THE REGISTRATION OF PROPERTY RIGHTS. THE DRAWING AS WELL AS THE MATTERS SHOWN ARE STRICTLY CONFIDENTIAL. REPRODUCTIONS MAY ONLY BE MADE FOR THE PURPOSE AGREED UPON. NEITHER THIS DRAWING NOR COPIES THEREOF MAY BE MADE ACCESSIBLE TO THIRD PARTIES. WITH THE DELIVERY OF THIS DRAWING NO RIGHT TO USE IT FOR ANY PURPOSE IS GRANTED. VIOLATIONS AGAINST THE OBLIGATIONS TO SECRECY AND USE RESTRICTIONS WILL BE PROSECUTED.		MAPAL Präzisionswerkzeuge Dr. Kress KG		DATE OF ISSUE 2018-12-10	CREATED KLA
BALANCE GRADE PER DIN ISO 21940-11 G 6.3 / 3000 MIN ⁻¹		GENERAL TOLERANCE ISO 2768-1H SIZE ISO 14405-1 (D)		DOCUMENT 607041012-000-02-ED1	
APPROX. 4.0 kg		DIMENSIONS NOT SHOWN ARE MAPAL STANDARDS		MATERIAL NUMBER 31002277	
		SCALE 1:1		TECHNICAL SPECIFICATION 1CM900-160-C A40-Z16R-SN.U12	
				SHEET 1/1	